

**Position Marker
for touchless
Rotary Sensors**

Z-RFC-P41

Position marker for frontal fixation with 2 cylinder head screws M4x20 (with screw lock) or with locking pin (both included in delivery).

- max. permitted radial offset ± 3 mm
- operating temp. $-40 \dots +125^\circ \text{C}$
- packaging unit:
1 pc. P/N 400105037
25 pcs. P/N 400105038

Z-RFC-P02

Position marker for frontal fixation with 2 cylinder head screws M4x20 (with screw lock) or with locking pin (included in delivery)

- max. permitted radial offset ± 3 mm
- operating temp. $-40 \dots +125^\circ \text{C}$
- packaging unit:
1 pc. P/N 400005661
25 pcs. P/N 400056080

Z-RFC-P47

Position marker for frontal fixation with 2 cylinder head screws M4x20 (with screw lock) or with threaded pin M5 (both included in delivery).

- max. permitted radial offset ± 3 mm
- operating temp. $-40 \dots +125^\circ \text{C}$
- packaging unit:
1 pc. P/N 400105039
25 pcs. P/N 400105040

Z-RFC-P08

Position marker for fixation with threaded pin pin M5 (included in delivery)

- max. permitted radial offset ± 3 mm
- operating temp. $-40 \dots +125^\circ \text{C}$
- packaging unit:
1 pc. P/N 400056070
25 pcs. P/N 400056084

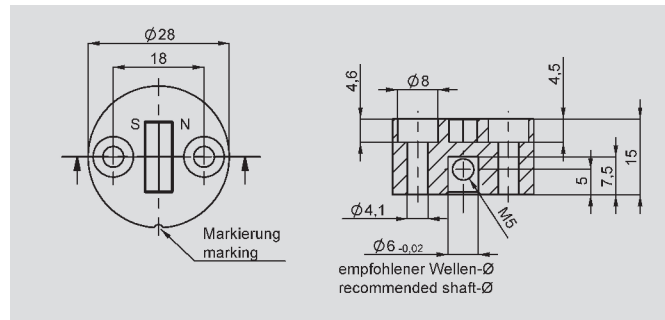
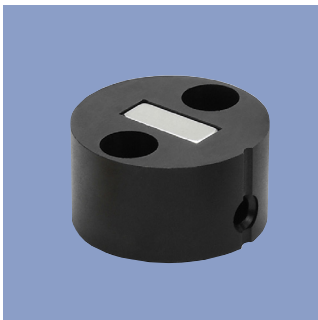
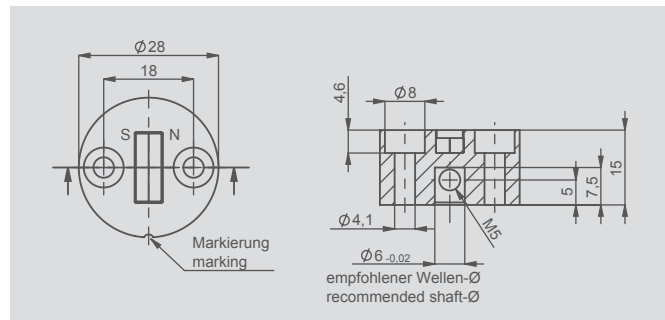
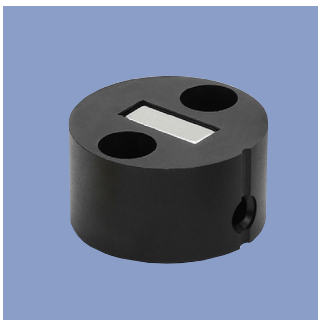
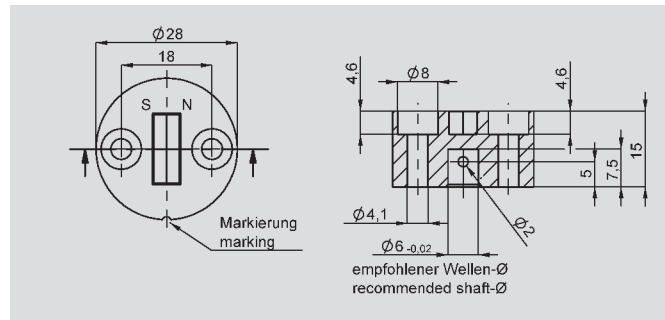
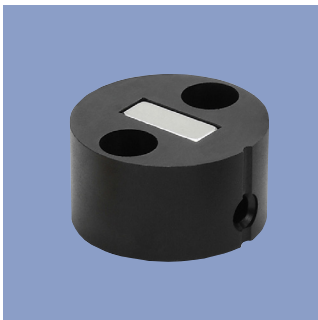
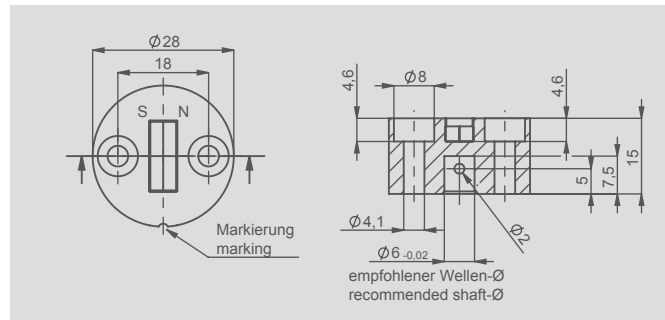
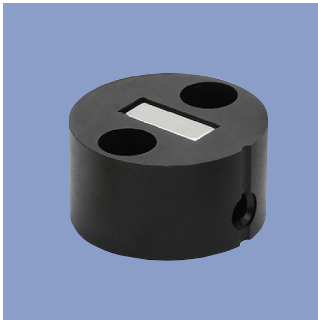

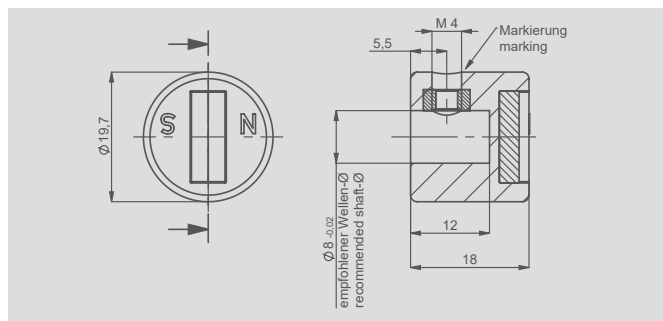

Z-RFC-P43

Position marker for fixation with threaded pin M4 (included in delivery).
Caution: For orientation of the output characteristic please follow the user manual of the position marker!

- max. permitted radial offset ± 3 mm
- operating temp. $-40 \dots +125^\circ \text{C}$
- packaging unit:
1 pc. P/N 400105041
25 pcs. P/N 400105042

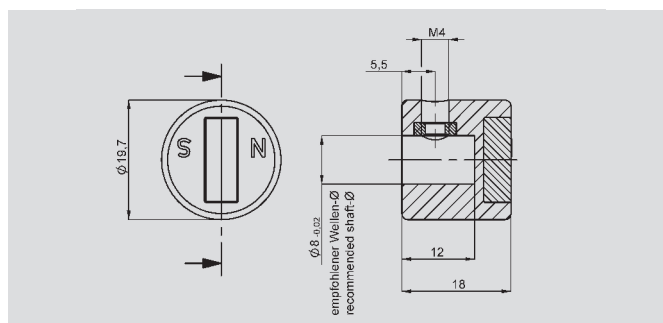

Z-RFC-P23

Position marker for fixation with threaded pin M4 (included in delivery).
Caution: For orientation of the output characteristic please follow the user manual of the position marker!

- max. permitted radial offset ± 3 mm
- operating temp. $-40 \dots +125^\circ \text{C}$
- packaging unit:
1 pc. P/N 400056074
25 pcs. P/N 400056085

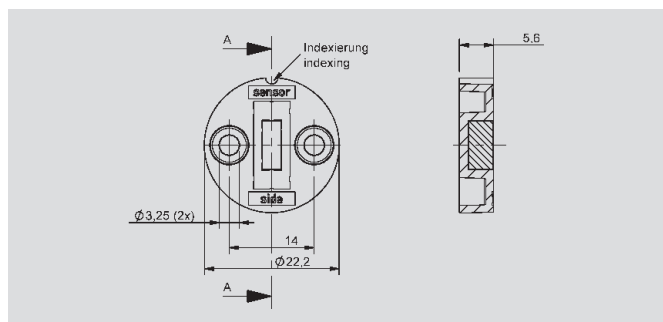

Z-RFC-P30

Position marker for frontal fixation with 2 fillister screws M3x8 (included in delivery)

- max. permitted radial offset ± 1.5 mm
- operating temp. $-40 \dots +125^\circ \text{C}$
- packaging unit:
1 pc. P/N 400056086
25 pcs. P/N 400056087

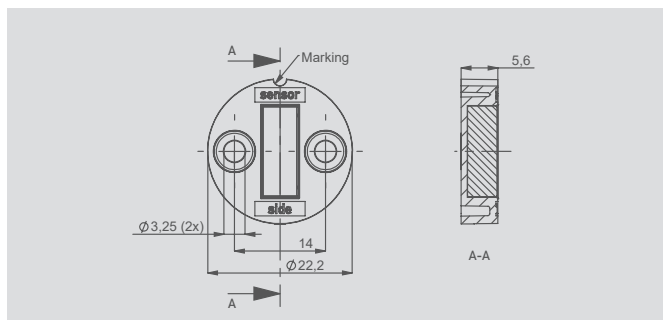

Z-RFC-P31

Position marker for frontal fixation with 2 fillister screws M3x8 (included in delivery)

- max. permitted radial offset ± 3 mm
- operating temp. $-40 \dots +125^\circ \text{C}$
- packaging unit:
1 pc. P/N 400056088
25 pcs. P/N 400056089

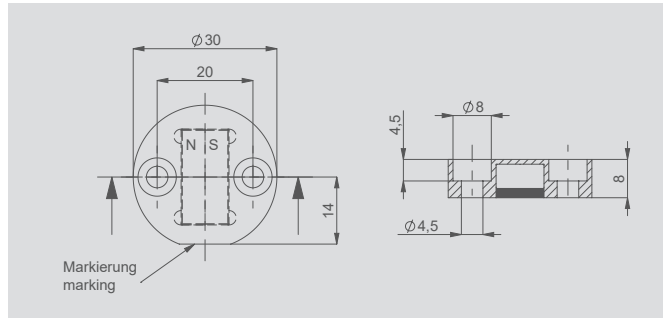
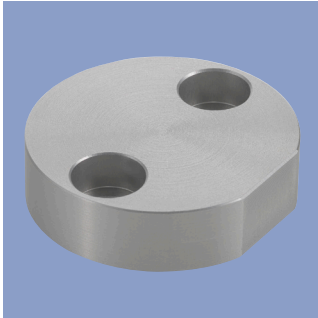

Z-RFC-P22

Position marker for frontal fixation with 2 cylinder head screws M4x20 (with screw lock, included in delivery). Attention: Closed side of position marker faces the active side of sensor. Aluminum anodized, magnet potted

- Max. permitted radial offset ± 4 mm
- operating temp. $-40 \dots +125^\circ \text{C}$
- packaging unit:
1 pc. P/N 400106735
25 pcs. P/N 400106736

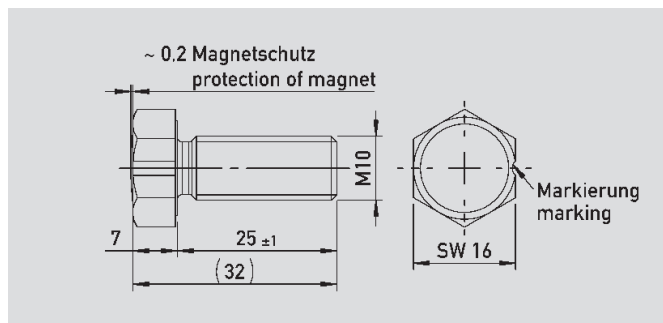
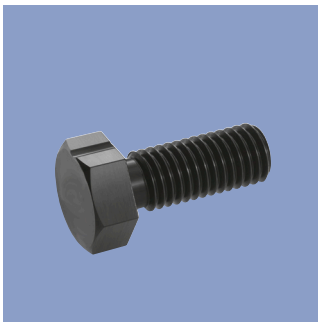

Z-RFC-P18

Screw position marker M10 x 25 mm. similar DIN 933. Aluminum anodized, magnet potted

- max. permitted radial offset ± 3 mm
- operating temp. $-40 \dots +125^\circ \text{C}$
- packaging unit:
1 pc. P/N 400104756
25 pcs. P/N 400104757

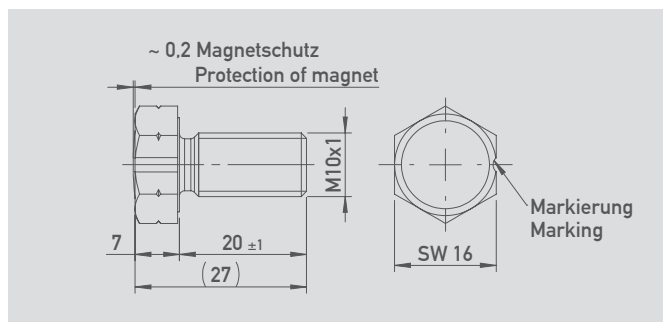
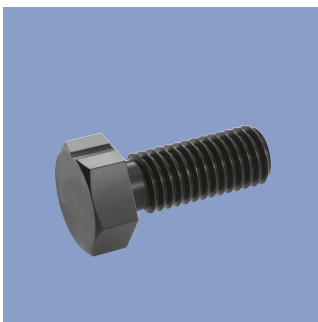

Z-RFC-P28

Screw position marker M10x1 x 20 mm. similar DIN 933. Aluminum anodized, magnet potted

- max. permitted radial offset ± 3 mm
- operating temp. $-40 \dots +125^\circ \text{C}$
- packaging unit:
1 pc. P/N 400108462
25 pcs. P/N 400108463

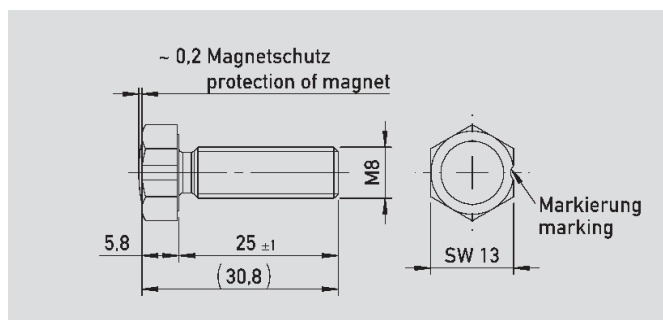
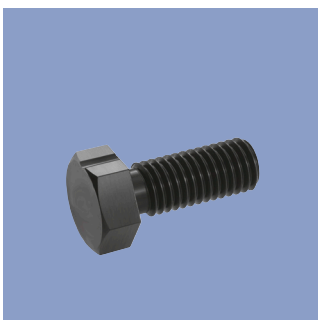

Z-RFC-P19

Screw position marker M8 x 25 mm. similar DIN 933 / ISO 4017. Aluminum anodized, magnet potted

- max. permitted radial offset ± 1.5 mm
- operating temp. $-40 \dots +125^\circ \text{C}$
- packaging unit:
1 pc. P/N 400104754
25 pcs. P/N 400104755

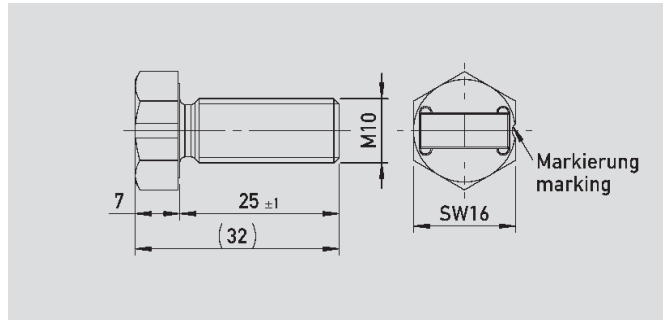
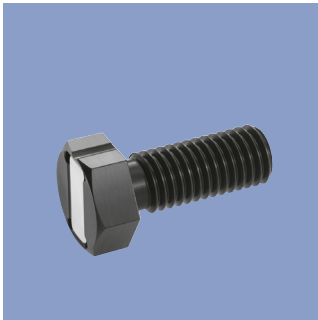

Z-RFC-P20

Screw position marker
M10 x 25 mm, similar DIN 933.
Aluminum anodized.

- max. permitted radial offset ±3 mm
- operating temp. -40 ... +125° C
- packaging unit:
1 pc. P/N 400104758
25 pcs. P/N 400104759

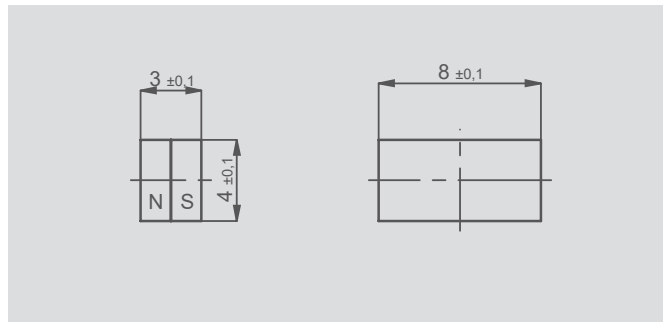
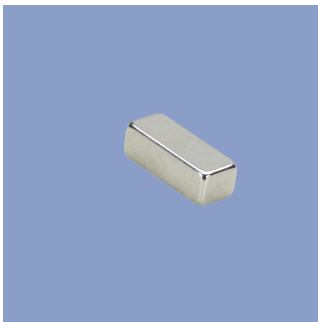

Z-RFC-P03

Magnet for direct application onto customer's shaft

- max. permitted radial offset ±1.5 mm
- operating temp. -40 ... +125° C
- packaging unit:
1 pc. P/N 400005658
50 pcs. P/N 400056081

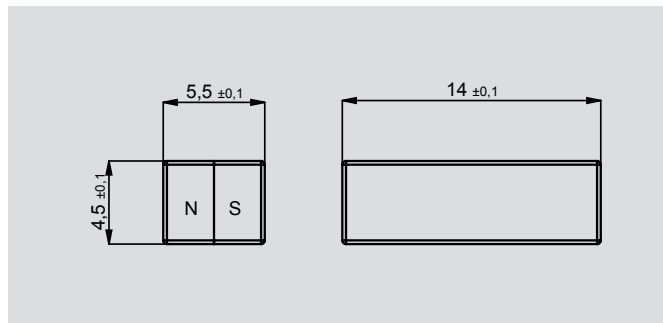

Z-RFC-P04

Magnet for direct application onto customer's shaft

- max. permitted radial offset ±3 mm
- operating temp. -40 ... +125° C
- packaging unit:
1 pc. P/N 400005659
50 pcs. P/N 400056082

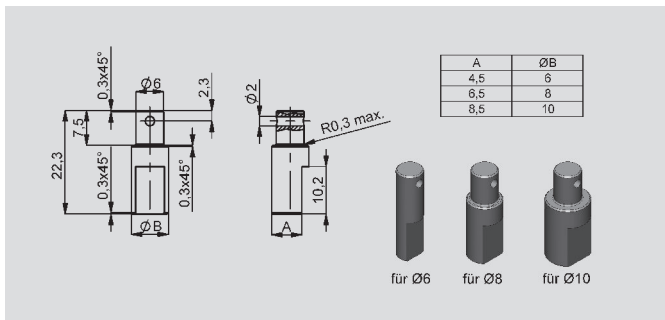

Shaft adapter for Z-RFC-P01 / P02 / P41

Fixation at position marker with locking pin

- Z-RFC-S01: Ø 6 mm. P/N 400056206
- Z-RFC-S02: Ø 8 mm. P/N 400056207
- Z-RFC-S03: Ø 10 mm. P/N 400056208

Mounting instructions Z-RFC-P03 / Z-RFC-P04

- In general, we recommend mounting on not magnetizable materials, otherwise the stated working distances can change
- If the shaft is magnetizable please keep sufficient distance
- When the magnet is mounted in the shaft, the shaft may not be magnetizable
- If the magnet is axially fixed on a magnetizable shaft the working distances reduces by approximately 20 %



Working distances (mm)

Series	Interface	Z-RFC- _ _ _		P04 / P23 / P31 / P20	P02 / P08	P41 / P47	P43	P22	P18 / P28	P19
		P30	P03							
RFC-4801/4802 4853/4854 4861/4862	analog single SPI	0 ... 1.5		0 ... 4		0 ... 2.7		-	0 ... 4.5	0 ... 2.2
RFC-4801/4802 4853/4854 4861/4862	analog redundant	0 ... 1.5		0 ... 4		0 ... 2.3		-	0 ... 4	0 ... 1.7
RFC-4801/4802	SSI / Incremental	-		0 ... 1.4		-		-	-	-
RFC-4851/4852	analog single CAN single IO-Link single	0.7 ... 2.2		2.3 ... 5		0 ... 2.7		4.4 ... 9.2	0 ... 4.5	0 ... 2.2
RFC-4851/4852	analog redundant CAN redundant	0.3 ... 1.8		1.9 ... 4.5		0 ... 2.3		4.8 ... 8.8	0 ... 4	0 ... 1.7
RFC-4863/4864	analog single	0.7 ... 2.2		2.3 ... 5		0 ... 2.7		-	0 ... 4	0 ... 2.2
RFC-4863/4864	analog redundant	0.3 ... 1.8		1.9 ... 4.5		0 ... 2.3		-	0 ... 3.5	0 ... 1.7
RFD-4021/4031	analog single	1.2 ... 2.7	1 ... 3	2.8 ... 6.2	-	-	0.9 ... 3.4	6.1 ... 10.9	0 ... 5	0 ... 2.8
RFD-4021/4031	analog redundant	0.7 ... 2.3	0.6 ... 2.6	2.8 ... 6.2	-	-	0.5 ... 2.9	5.6 ... 10.4	0 ... 4.5	0 ... 2.3
RFX-6901	analog single / redundant CAN redundant	-	-	0.3 ... 3.5		-		2.6 ... 7.3	0 ... 2.5	-
RFX-6901	CAN single	-	-	0.8 ... 4		-		2.9 ... 7.7	0 ... 3	-
RFE-3201	analog single CAN single	0.4 ... 1.9	-	2 ... 4.7	-	-	0 ... 2.4	4.1 ... 8.9	0 ... 4	0 ... 1.8
RFE-3201	analog redundant CAN redundant	0.5 ... 1.5	-	1.6 ... 4.2	-	-	0 ... 2	3.6 ... 8.4	0 ... 3.5	0 ... 1.3

Addition linearity error (°) at radial displacement

Series	Interface	Z-RFC-P02 / P04 / P08 / P20 / P23 / P31			Z-RFC-P41 / P43 / P47			Z-RFC-P03 / P30			Z-RFC-P18 / P28			Z-RFC-P19			Z-RFC-P22		
		0.5 mm	1 mm	2 mm	0.5 mm	1 mm	2 mm	0.5 mm	1 mm	2 mm	0.5 mm	1 mm	2 mm	0.5 mm	1 mm	2 mm	1 mm	2 mm	4 mm
		RFC-48 _ _ RFD-4021 RFE-3201 RFX-6901	analog single* SPI CANopen single IO-Link single	0.4	1.1	3.5	0.4	1.1	3.5	1.4	3.7	-	0.7	1.3	3.3	1.3	2.6	-	0.8
RFC-48 _ _ RFD-4021 RFE-3201 RFX-6901	analog redundant* CANopen redundant	0.7	1.8	5.2	0.7	1.8	5.2	2.5	6.4	-	1.1	2	4.6	2.3	4.5	-	1.1	2.4	6.7
RFX-6901	analog single analog redundant	0.7	1.8	5.2	0.7	1.8	5.2	-	-	-	1.1	2	4.6	-	-	-	1.1	2.4	6.7
RFC-48 _ _	SSI Incremental	0.4	0.7	2.2	-	-	-	-	-	-	-	-	-	-	-	-	-	-	-

*) except RFX

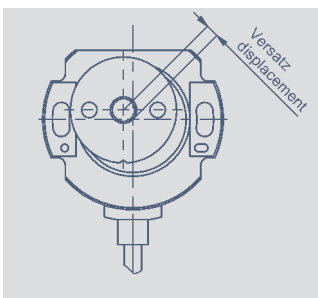

Lateral magnet offset (will cause additional linearity error)

The angle error, which is caused by radial displacement of sensor and position marker depends on the used position marker or magnet.

The specifications contained in our datasheets are intended solely for informational purposes. The documented specification values are based on ideal operational and environmental conditions and can vary significantly depending on the actual customer application. Using our products at or close to one or more of the specified performance ranges can lead to limitations regarding other performance parameters. It is therefore necessary that the end user verifies relevant performance parameters in the intended application. We reserve the right to change product specifications without notice.