

**NOVOHALL
Rotary Sensor
Touchless**

RFC-4800
4 ... 20 mA
Industrial

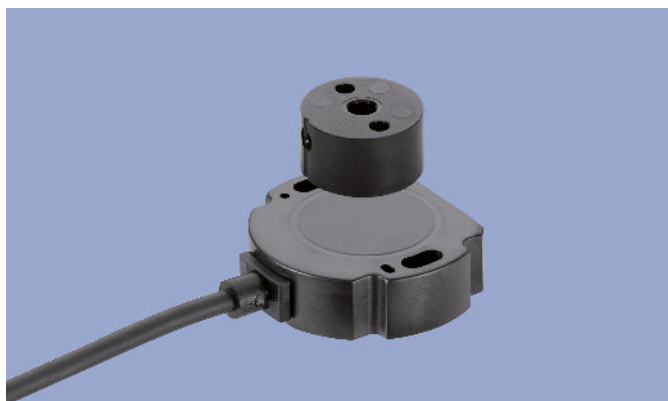
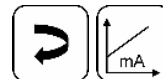

Special Features

- Touchless hall technology
- Electrical range up to 360°
- 2 part design, mechanically decoupled
- High protection class IP67, IP68, IP69
- Resolution 12 bit
- Wear-free
- Temperature range -40 °C to +105 °C
- Optimized for use in industrial applications
- Other configurations see separate data sheets

Applications

- Manufacturing Engineering (textile machinery, packaging machinery, sheet metal and wire machinery)
- Automation technology
- Medical Engineering

The 2 part design consisting of sensor and magnetic position marker offers great flexibility when mounting. The absence of shaft and bearing makes the assembly much less sensitive to axial and radial application tolerances - separate couplings are obsolete. Measurements can be made transmissively through any non-ferromagnetic material. The sensor is perfectly suitable for use in harsh environmental conditions through the completely encapsulated electronics.

Description

Material	Housing: high grade, temperature resistant plastic
Mounting	With 2 pan head screws M4x20 (included in delivery)
Fastening torque of mounting	250 Ncm
Electrical connection	Connector M12x1, A-coded with cable L = 0.15 m / Cable 4x 0.5 mm ² (AWG 20), TPE, shielded

Mechanical Data

Dimensions	See dimension drawing
Mechanical travel	continuous
Weight (w/o connection)	approx. 50 g

Ordering Specifications

Ordering Specifications

Preferred types printed in bold

- Delivery time up to 25 pcs. within 10 working days EXW
- Best low-volume pricing

Supply voltage U_b

1: $U_b = 24$ VDC

Output signal

2: 4 ... 20 mA

Output characteristic

1: Rising output characteristic cw

2: Rising output characteristic ccw

Other output characteristics on request

Electrical connection

201: Cable, 4-pole, shielded, L = 0.5 m

202: Cable, 4-pole, shielded, L = 1 m

206: Cable, 4-pole, shielded, L = 3 m

210: Cable, 4-pole, shielded, L = 5 m

220: Cable, 4-pole, shielded, L = 10 m

501: Connector M12x1, 4-pin, with cable, shielded, L = 0.15 m

Cable versions and assembled connectors on request

R F C - 4 8 5 1 - 6 3 6 - 1 2 1 - 2 0 2

Series

Mechanical version

4851: Elongated hole mounting for easy adjustment

4852: Round hole mounting

4853: Elongated hole mounting, without diagnostic function

4854: Round hole mounting, without diagnostic function

Other configurations e.g. with internal shielding against magnetic fields on request

Measuring range

03: Angle 0° ... 30° min.

...

06, 12, 18, 24, 36

...

36: Angle 0° ... 360° max.

Other angles on request

Number of channels

6: One-channel version (1x supply voltage U_b / 1x output)

Accessories included in delivery

- 2x Pan head screws M4x20

Drawing

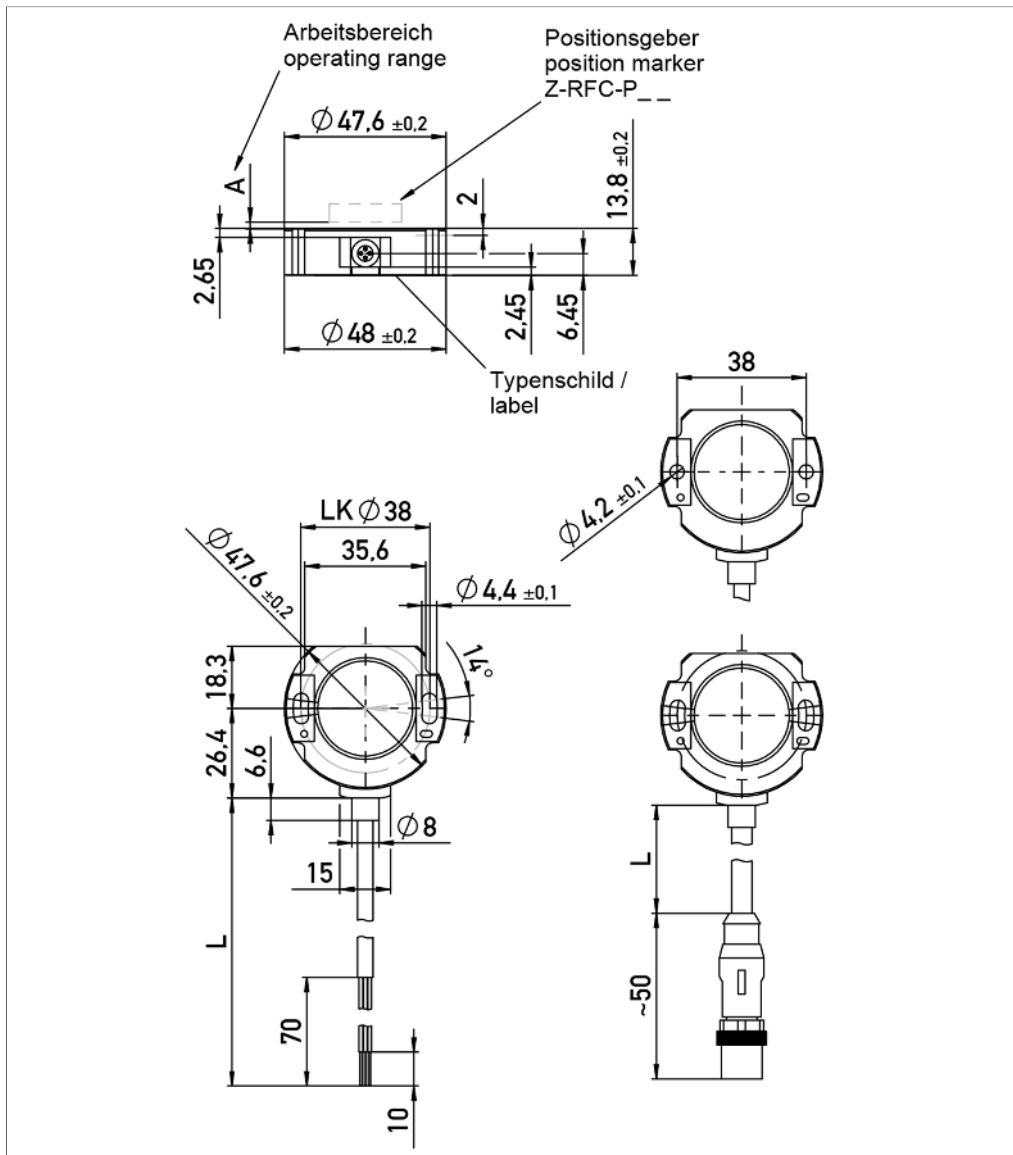

CAD data see
www.novotechnik.de/en/download/cad-data/

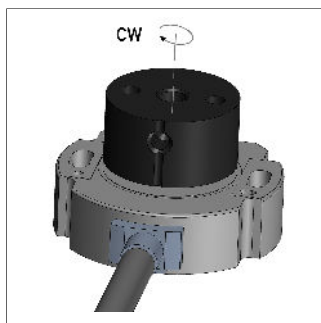

When the marking of the position marker is pointing towards the cable, the sensor output is near the electrical center position (index position).

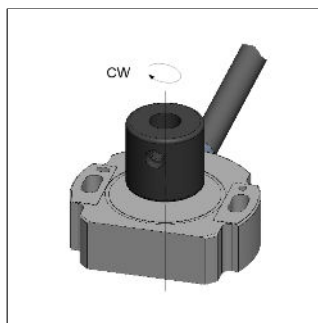

Only Z-RFC-P23/P43:
When the marking of the position marker is pointing away from the cable, the sensor output is near the electrical center position (index position).

Technical Data

Type	RFC-48 _ _ _ _ -12 _ _ _ _ Analog current
Output signal	4 ... 20 mA
Burden	≤ 500 Ω
Diagnosis	activated (in case of error, output signal is outside of the plausible signal range)
Update rate	typ. 3.4 kHz
Measuring range	0 ... 30° up to 0 ... 360° in 10°-steps
Independent linearity	≤ ±0.5 %FS
Resolution	12 bits
Repeatability	typ. ≤ ±0.1°
Hysteresis	typ. < ±0.1° Only measuring range 360°: typ. < 0.25° (lower hysteresis on request)
Temperature error	Measuring range 30 ... 170°: typ. ±1.2 %FS, Measuring range ≥ 180°: typ. ±0.6 %FS
Supply voltage Ub	24 VDC (13 ... 30 VDC)
Current consumption w/o load	typ. 12 mA per channel
Polarity protection	yes (supply lines and outputs)
Short circuit protection	yes (vs. GND and supply voltage Ub)
Insulation resistance (500 VDC)	≥ 10 MΩ
Environmental Data	
Max. operational speed	Mechanically unlimited
Vibration IEC 60068-2-6	20 g, 5 ... 2000 Hz, Amax = 0.75 mm
Shock IEC 60068-2-27	50 g, 6 ms
Protection class DIN EN 60529	IP67 (connector M12), IP67 / IP68 / IP69
Operating temperature	-25 ... +85°C (connector M12), -40 ... +105°C* * The max. operating temperature depends on supply voltage Ub and load resp. burden (see temp.diagram)
Life	Mechanically unlimited
Functional safety	If you need assistance in using our products in safety-related systems, please contact us
MTTF (IEC 60050)	798 years
Traceability	Serial number on type labeling: production batch of the sensor assembly and relevant sensor components
Conformity/Approval	CE, UKCA see https://www.novotechnik.de/en/downloads/certificates/declarations-of-conformity-eu/uk WEEE see https://www.novotechnik.de/en/downloads/certificates/eu-directive-weee/

EMC Compatibility	
EN 61000-4-2 ESD (contact/air discharge)	4 kV, 8 kV
EN 61000-4-3 Electromagnetic fields (RFI)	10 V/m
EN 61000-4-4 Fast transients (burst)	1 kV
EN 61000-4-6 Cond. disturbances (HF fields)	10 V eff.
EN 55016-2-3 Radiated disturbances	Industrial and residential area

FS = Full scale: Signal span according to electrical measuring range

Connection Assignment

Signal	Connector code 5_ _	Cable code 2_ _
Supply voltage Ub	Pin 1	GN
GND	Pin 3	BN
Signal output	Pin 2	WH
Not assigned	Pin 4	YE

Connect cable shielding to GND

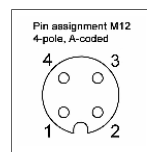

Technical Data Output Characteristics

Temperature Diagram

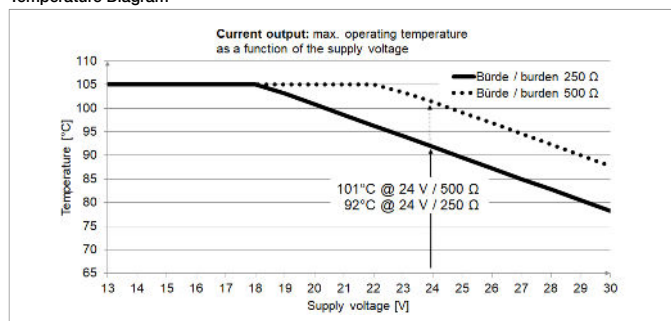

Output characteristic

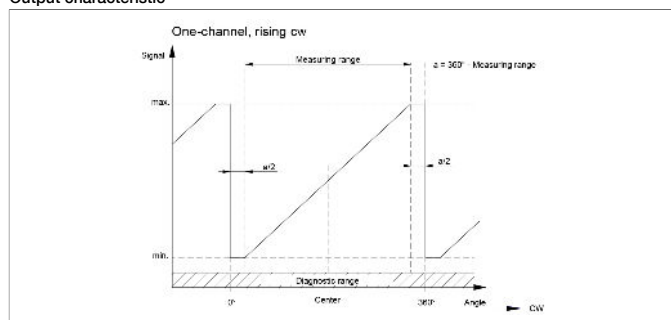

Output characteristic

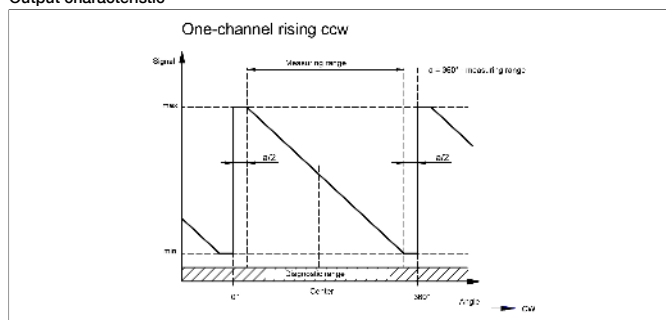

Output characteristic

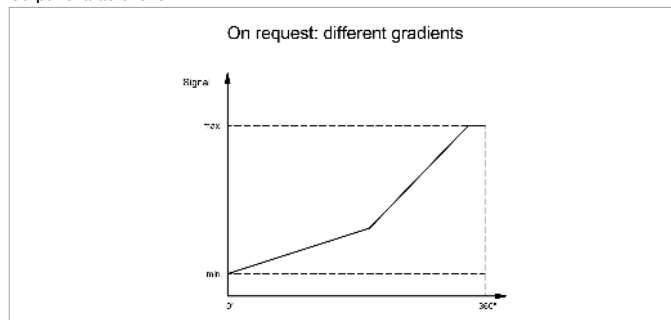

Output characteristic

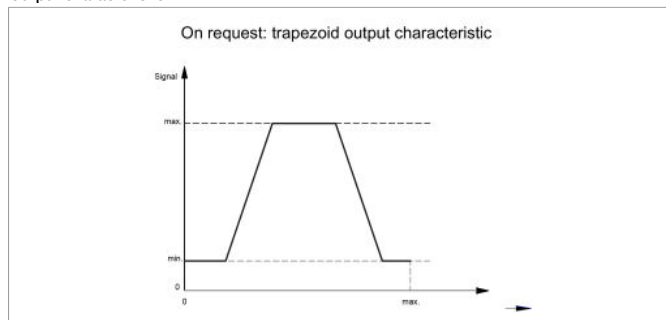

Output characteristic

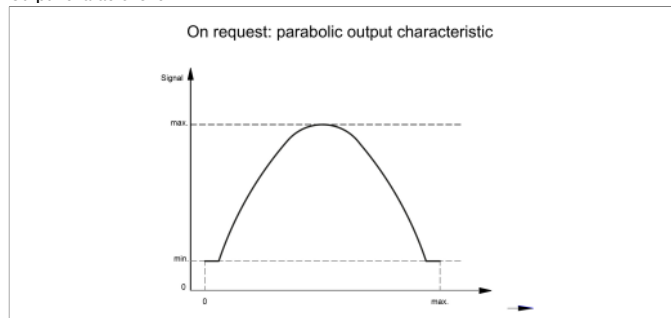

Position Markers

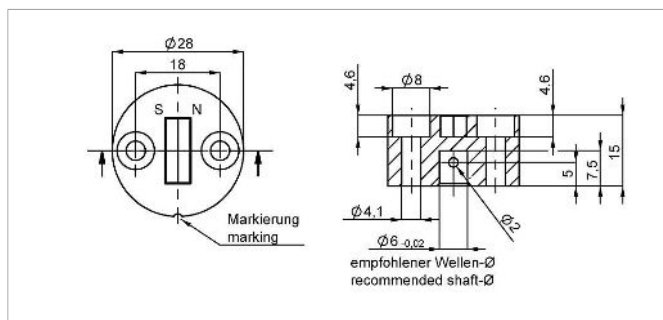

Z-RFC-P02

Position marker for frontal fixation with 2 cylinder head screws M4x20 (with screw lock) or with locking pin (both included in delivery).

Material PF
Max. permitted ± 3 mm
radial offset
Operating temp. $-40 \dots +125^{\circ}\text{C}$

P/N	Pack. unit [pcs]
40005661	1
400056080	25

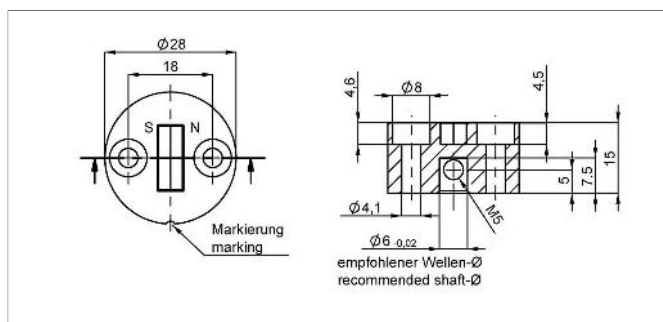

Z-RFC-P08

Position marker for fixation with threaded pin M5 (included in delivery).

Material PF
Max. permitted ± 3 mm
radial offset
Operating temp. $-40 \dots +125^{\circ}\text{C}$

P/N	Pack. unit [pcs]
400056070	1
400056084	25

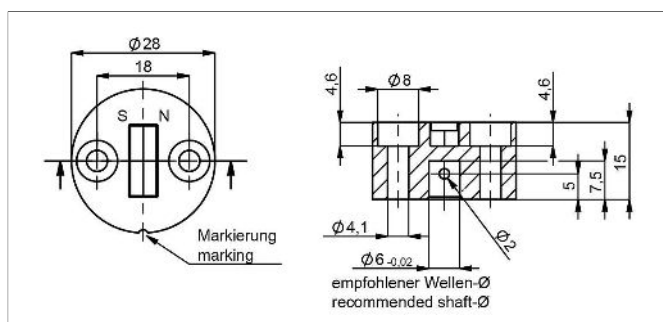
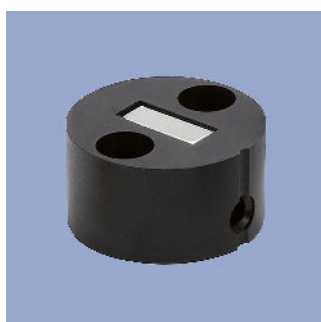

Z-RFC-P41

Position marker for frontal fixation with 2 cylinder head screws M4x20 (with screw lock) or with locking pin (both included in delivery).

Material PF
Max. permitted ± 3 mm
radial offset
Operating temp. $-40 \dots +125^{\circ}\text{C}$

P/N	Pack. unit [pcs]
400105037	1
400105038	25

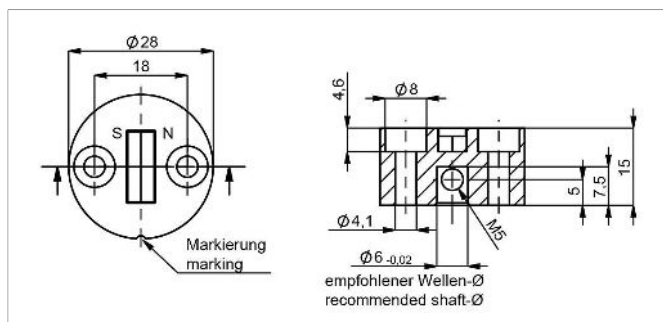

Z-RFC-P47

Position marker for frontal fixation with 2 cylinder head screws M4x20 (with screw lock) or with threaded pin M5 (both included in delivery).

Material PF
Max. permitted ± 3 mm
radial offset
Operating temp. $-40 \dots +125^{\circ}\text{C}$

P/N	Pack. unit [pcs]
400105039	1
400105040	25

Position Markers

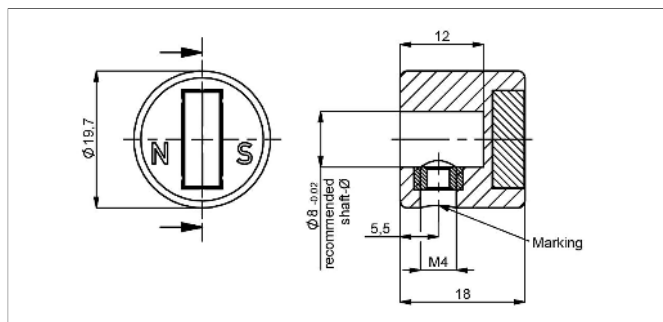

Z-RFC-P23

Position marker for fixation with threaded pin M4 (included in delivery)

Caution: For orientation of the output characteristic please follow the user manual of the position marker!

Material PA6-GF

Max. permitted ± 3 mm

radial offset

Operating temp. $-40 \dots +125^\circ\text{C}$

P/N	Pack. unit [pcs]
400056074	1
400056085	25

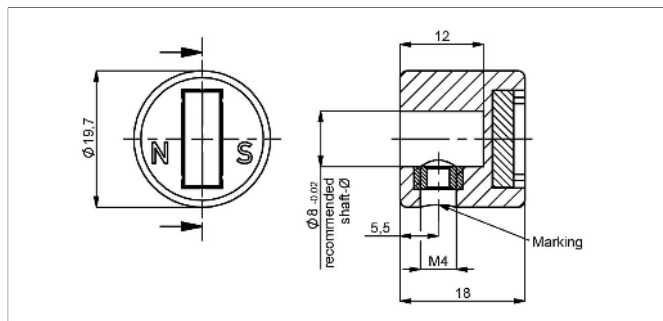

Z-RFC-P43

Position marker for fixation with threaded pin M4 (included in delivery)

Caution: For orientation of the output characteristic please follow the user manual of the position marker!

Material PA6-GF

Max. permitted ± 3 mm

radial offset

Operating temp. $-40 \dots +125^\circ\text{C}$

P/N	Pack. unit [pcs]
400105041	1
400105042	25

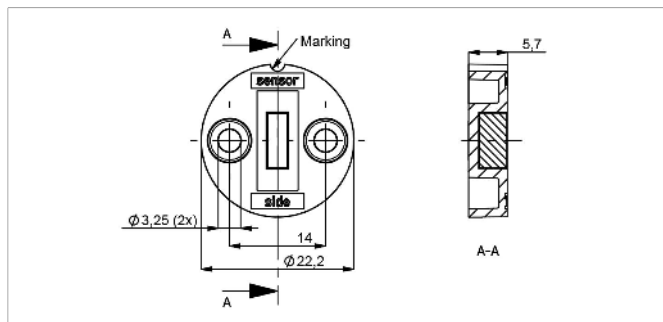

Z-RFC-P30

Position marker for frontal fixation with 2 cylinder screws M3x8 (included in delivery).

Material PBT-GF

Max. permitted ± 1.5 mm

radial offset

Operating temp. $-40 \dots +125^\circ\text{C}$

P/N	Pack. unit [pcs]
400056086	1
400056087	25

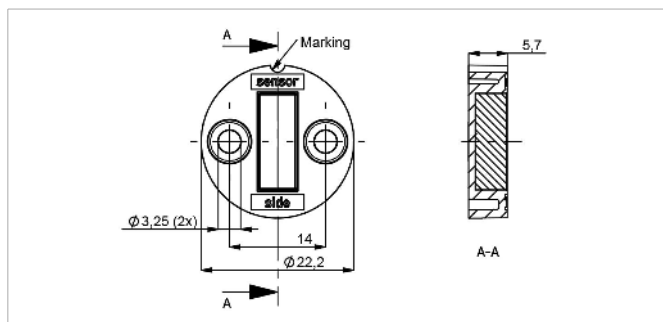

Z-RFC-P31

Position marker for frontal fixation with 2 cylinder screws M3x8 (included in delivery).

Material PBT-GF

Max. permitted ± 3 mm

radial offset

Operating temp. $-40 \dots +125^\circ\text{C}$

P/N	Pack. unit [pcs]
400056088	1
400056089	25

Position Markers

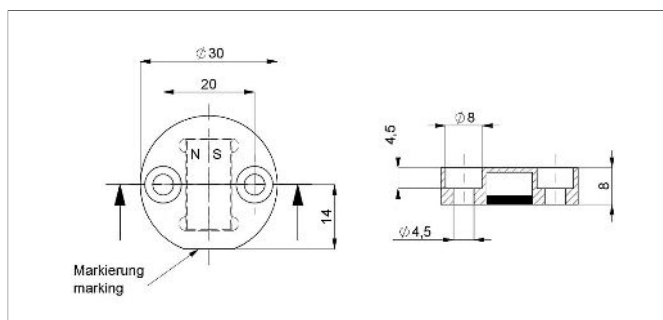
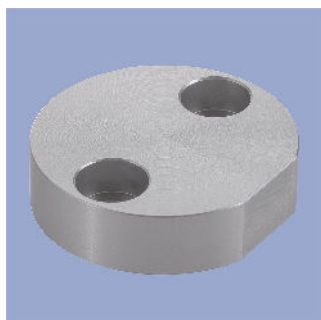

Z-RFC-P22

Position marker for frontal fixation with 2 cylinder head screws M4x20 (with screw lock, included in delivery).

Attention: Closed side of position marker faces the active side of sensor.

Material Aluminium, anodized
Max. permitted radial offset ± 4 mm
Operating temp. $-40 \dots +125^\circ\text{C}$

P/N	Pack. unit [pcs]
400106735	1
400106736	25

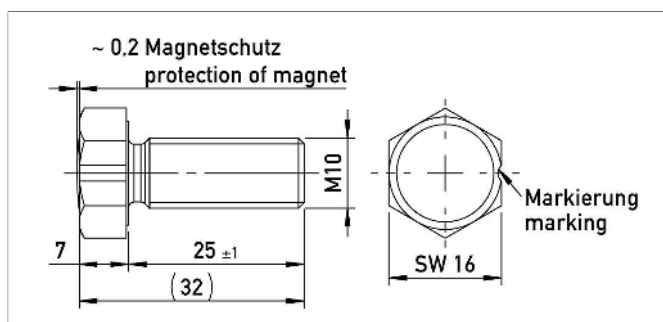

Z-RFC-P18

Screw position marker M10 x 25 mm, similar DIN 933, magnet potted

Material Aluminium, anodized
Max. permitted radial offset ± 3 mm
Operating temp. $-40 \dots +125^\circ\text{C}$

P/N	Pack. unit [pcs]
400104756	1
400104757	25

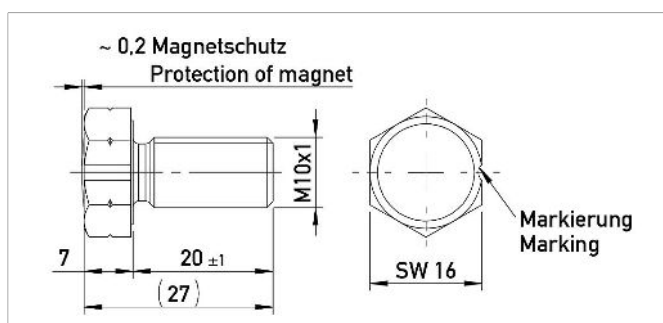

Z-RFC-P28

Screw position marker M10x1 x 20 mm, similar DIN 933, magnet potted

Material Aluminium, anodized
Max. permitted radial offset ± 3 mm
Operating temp. $-40 \dots +125^\circ\text{C}$

P/N	Pack. unit [pcs]
400108462	1
400108463	25

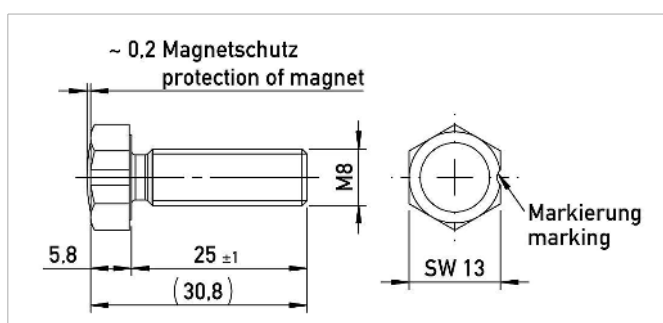

Z-RFC-P19

Screw position marker M8 x 25 mm, similar DIN 933/ISO 4017, magnet potted

Material Aluminium, anodized
Max. permitted radial offset ± 1.5 mm
Operating temp. $-40 \dots +125^\circ\text{C}$

P/N	Pack. unit [pcs]
400104754	1
400104755	25

Position Markers

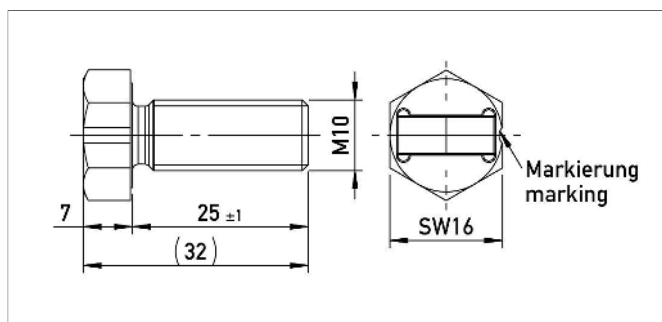

Z-RFC-P20

Screw position marker M10 x 25 mm, similar DIN 933

Material Aluminium, anodized

Max. permitted radial offset ± 3 mm

Operating temp. -40 ... +125°C

P/N	Pack. unit [pcs]
400104758	1
400104759	25

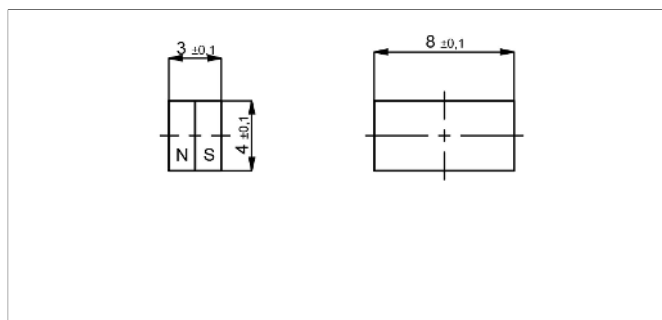
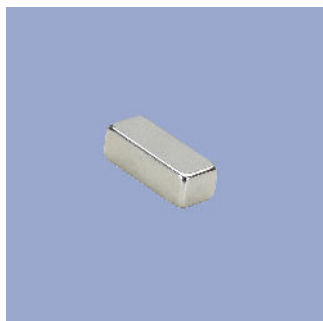

Z-RFC-P03

Magnet for direct application onto customer's shaft (see user manual).

We recommend mounting on non-magnetizable materials, otherwise the specified working distances will vary (e.g. reduction of approx. 20% with axial mounting on a magnetizable shaft).

Max. permitted radial offset ± 1.5 mm

Operating temp. -40 ... +125°C

P/N	Pack. unit [pcs]
400005658	1
400056081	50

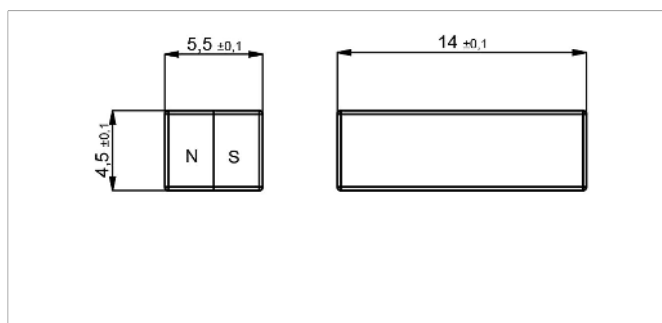

Z-RFC-P04

Magnet for direct application onto customer's shaft (see user manual).

We recommend mounting on non-magnetizable materials, otherwise the specified working distances will vary (e.g. reduction of approx. 20% with axial mounting on a magnetizable shaft).

Max. permitted radial offset ± 3 mm

Operating temp. -40 ... +125°C

P/N	Pack. unit [pcs]
400005659	1
400056082	50

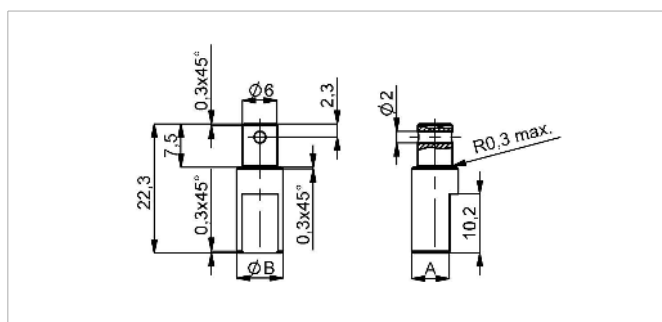
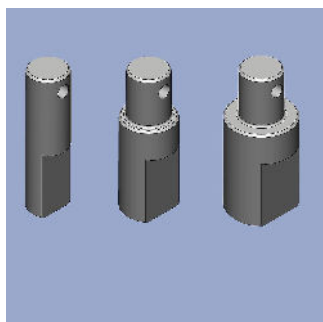

Z-RFC-S01/S02/S03

Shaft adapter for fixation at position marker Z-RFC-P02/P41 with locking pin

Material Stainless steel 1.4305

P/N	Type	ØB / A [mm]
400056206	Z-RFC-S01	6 / 4.5
400056207	Z-RFC-S02	8 / 6.5
400056208	Z-RFC-S03	10 / 8.5

Position Markers

Working Distances Position Markers [mm] - One-channel Versions

	Z-RFC-P02 / P04 / P08 Z-RFC-P20 / P23 / P31	Z-RFC-P41 / P43 / P47	Z-RFC-P03 / P30	Z-RFC-P18 / P28	Z-RFC-P19	Z-RFC-P22
RFC-4851	2.3 ... 5	0 ... 2.7	0.7 ... 2.2	0 ... 4.5	0 ... 2.2	4.4 ... 9.2
RFC-4852 with diagnosis						
RFC-4853	0 ... 4	0 ... 2.7	0 ... 1.5	0 ... 4.5	0 ... 2.2	4.4 ... 9.2
RFC-4854 w/o diagnosis						

Lateral Magnet Offset

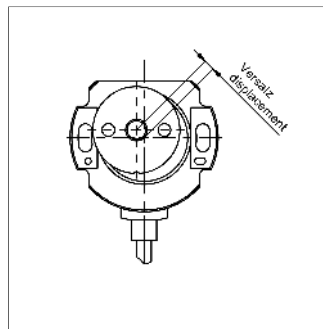

Lateral magnet offset will cause additional linearity error. The angle error, which is caused by radial displacement of sensor and position marker depends on the used position marker or magnet.

Additional Linearity Error at Radial Displacement - One-channel Versions

Z-RFC-P02 / P04 / P08 Z-RFC-P20 / P23 / P31	Z-RFC-P41 / P43 / P47	Z-RFC-P03 / P30	Z-RFC-P18 / P28	Z-RFC-P19	Z-RFC-P22
0.5 mm: $\pm 0.4^\circ$	0.5 mm: $\pm 0.4^\circ$	0.5 mm: $\pm 1.4^\circ$	0.5 mm: $\pm 0.7^\circ$	0.5 mm: $\pm 1.3^\circ$	1.0 mm: $\pm 0.8^\circ$
1.0 mm: $\pm 1.1^\circ$	1.0 mm: $\pm 1.1^\circ$	1.0 mm: $\pm 3.7^\circ$	1.0 mm: $\pm 1.3^\circ$	1.0 mm: $\pm 2.6^\circ$	2.0 mm: $\pm 1.8^\circ$
2.0 mm: $\pm 3.5^\circ$	2.0 mm: $\pm 3.5^\circ$	2.0 mm: -	2.0 mm: $\pm 3.3^\circ$	2.0 mm: -	4.0 mm: $\pm 5.4^\circ$

Connector System M12

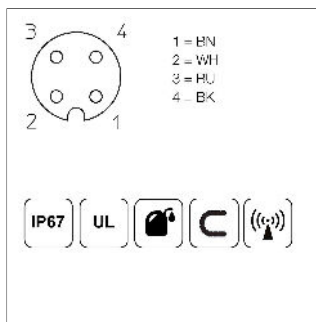
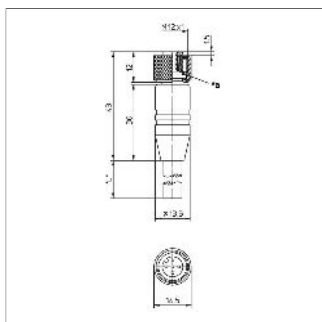
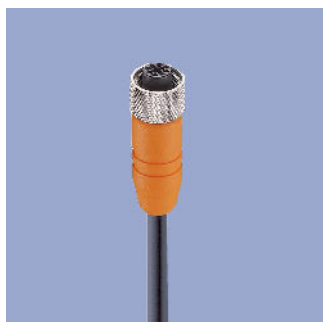

EEM-33-32/62/97
M12x1 Mating female connector, 4-pin, straight, A-coded, with molded cable, shielded, IP67, open ended

Plug housing PA
Cable sheath PUR, Ø = max. 6 mm, -25 ... +80°C (moved), -50 ... +80°C (fixed)

Lead wires PP, 0.34 mm²

P/N	Type	Length
400005600	EEM-33-32	2 m
400005609	EEM-33-62	5 m
400005650	EEM-33-97	10 m

IP67 Protection class IP67 DIN EN 60529

IP68 Protection class IP68 DIN EN 60529

(()) Very good Electromagnetic Compatibility (EMC) and shield systems

() Very good resistance to oils, coolants and lubricants

C Suited for applications in dragchains

UL UL - approved

CAN CAN-Bus

Signal Processing

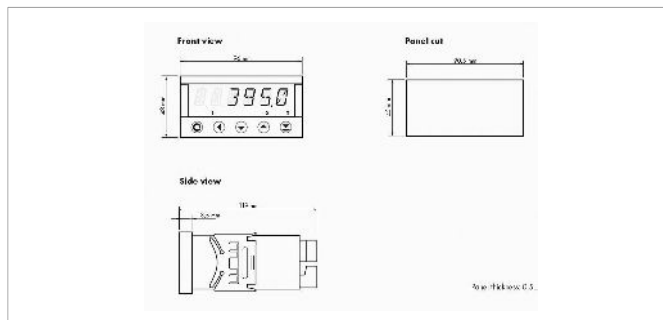

MAP-4000

Multifunctional measuring device with digital display for direct connection of potentiometric and normalized signals.

- Supply voltage 10...30 VDC, 80...250 VDC or AC
- High accuracy up to 0.1%
- Adjustable supply voltage for sensors 5...24 V
- Temperature coefficient 100 ppm/K
- Optional RS 232, RS 485, analog output, limited switch
- Complete data see separate data sheet

Connecting Options on request



- M12 connector**
- Customized lengths
 - 3-, 4-, 6- and 8-pole versions
 - Protection class IP68
 - Ordering codes of standard versions see ordering specifications

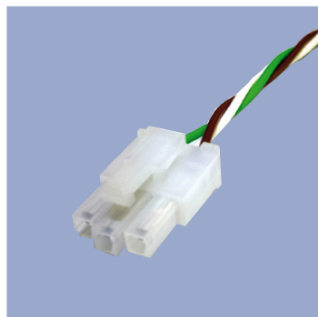

- Molex Mini Fit jr.**
- Customized length and lead wires
 - 3-, 4- and 6-pole versions
 - On request



- Tyco AMP Super Seal**
- Pin- and bushing housing
 - Customized lengths
 - 3-, 4- and 6-pole versions
 - Protection class IP67
 - On request



- Molex Mini Fit jr.**
- Customized length and lead wires
 - 3-, 4- and 6-pole versions
 - On request



- Deutsch DTM 04**
- Pin- and bushing housing
 - Customized lengths
 - 3-, 4- and 6-pole versions
 - Protection class IP67
 - On request



- ITT Cannon Sure Seal connector**
- Customized lengths
 - 3-, 4- and 6-pole versions
 - Protection class IP67
 - On request

Novotechnik
Messwertaufnehmer OHG
P.O.Box 4220
73745 Ostfildern (Germany)
Horbstrasse 12
73760 Ostfildern (Germany)
Phone +49 711 4489-0
Fax +49 711 4489-118
info@novotechnik.de
www.novotechnik.de



© Apr 10, 2026

The specifications contained in our datasheets are intended solely for informational purposes. The documented specification values are based on ideal operational and environmental conditions and can vary significantly depending on the actual customer application. Using our products at or close to one or more of the specified performance ranges can lead to limitations regarding other performance parameters. It is therefore necessary that the end user verifies relevant performance parameters in the intended application. We reserve the right to change product specifications without notice.