

**NOVOHALL  
Rotary Sensor  
Non-contacting**

**RSX-7900**

Heavy Duty

4 ... 20 mA

**Mobile Applications**

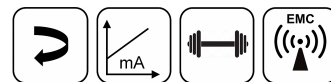

**Special Features**

- Very robust design for extreme environments
- High shaft load 300 N
- Non-contacting, magnetic encoder
- Measuring angles up to 360° in onee and multi-channel versions
- Enhanced corrosion protection due to anodized aluminum housing and stainless steel shaft, salt spray resistant
- Excellent linearity
- High resolution to 12 bit
- Unlimited mechanical rotation
- Absolutely impermeable to splash-water IP69K
- High temperature resistance
- Long life > 100 million movements, even in high vibration mounting positions
- For highest EMC requirements such as ISO pulses and interference fields, exceeds E1 requirements
- Suitable for use in safety-related applications according to ISO 13849

**Applications**

- Position measurement in steering systems
- Pivotable vehicle bracings
- Transport systems with several steered axes
- Construction and agricultural machinery

The angle sensor RSX-7900 is designed for use in mobile applications under extreme environmental conditions. The sensor is suitable for a continuously ambitious operating.

The robust full metal housing with a double ball bearing stainless steel shaft and a superior seal concept protects the sensor against various environmental influences.

The high accuracy and reliability of the magnetic angle measurement are further features, particularly in safety-related applications. The robust but compact design allows direct mounting of the sensor without additional protective measures.

A variety of shaft versions allows guidance via lever arm or other driving elements.

**Description**

Material	Housing: aluminium, anodized, AlMgSi1, salt spray resistant Shaft: stainless steel X10CrNiS18-9 1.4305
Mounting	With 4 screws M6, screw-in depth 15 mm min.
Fastening torque of mounting	800 ± 100 Ncm
Bearing	Double angular ball bearing
Electrical connection	Connector M12x1, A-coded / Cable with cable screw connection, 4x 0.5 mm <sup>2</sup> (AWG 20), TPE, unshielded

**Mechanical Data**

Dimensions	See dimension drawing
Mechanical travel	continuous
Permitted shaft load static or dynamic	300 N (axial / radial)
Torque	≤ 4 Ncm Depending on the environmental temperature and standstill time, the necessary force for the initial operating of the shaft may increase
Weight	approx. 500 g

## Ordering Specifications

### Ordering Specifications

Preferred types printed in bold

#### Supply voltage $U_b$

3:  $U_b = 12/24$  VDC

#### Output signal

8: 4 ... 20 mA

Other output signals on request

#### Output characteristic

1: Rising characteristic cw

2: Rising characteristic ccw

3: Crossed outputs, channel 1 rising cw (partly redundant)

4: Crossed outputs, channel 1 rising cw (fully redundant)

Other output characteristics on request

#### Electrical connection

One-channel / partly redundant version: 1 output

252: 1x cable 4-pole, 2 m, unshielded

551: 1x connector M12, 4-pin, unshielded

Fully redundant version: 2 outputs

352: 2x cable 4-pole, 2 m, unshielded

651: 2x connector M12, 4-pin, unshielded

Cable versions and assembled connectors on request

**R S X - 7 9 1 1 - 8 3 6 - 3 8 4 - 6 5 1**

Series

#### Measuring range

06: Angle 60°

12: Angle 120°

18: Angle 180°

24: Angle 240°

30: Angle 300°

36: Angle 360°

Other angles on request

#### Number of channels

6: One-channel version (1x supply voltage  $U_b$ , 1x output)

7: Partly redundant version (1x supply voltage  $U_b$ , 2x output)

8: Fully redundant version (2x supply voltage  $U_b$ , 2x output)

#### Shaft

1:  $\varnothing 13 \times 12$  mm with cross hole  $\varnothing 4,1$  mm

3:  $\varnothing 10 \times 16$  mm with countersink  $\varnothing 4.5 \times 90^\circ$

7:  $\varnothing 13 \times 12$  mm with mounted driving plate Z-IPX-M21

Other shaft configurations on request

#### Housing

1: Centering shaft side

4: Centering shaft and cover side

#### Model / size

79: 79 x 35 mm

**Drawing**

CAD data see  
[www.novotechnik.de/en/download/cad-data/](http://www.novotechnik.de/en/download/cad-data/)

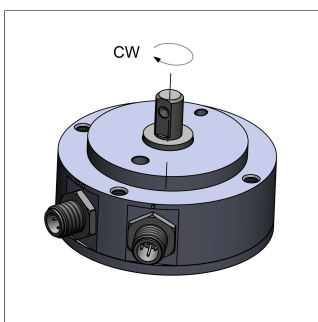
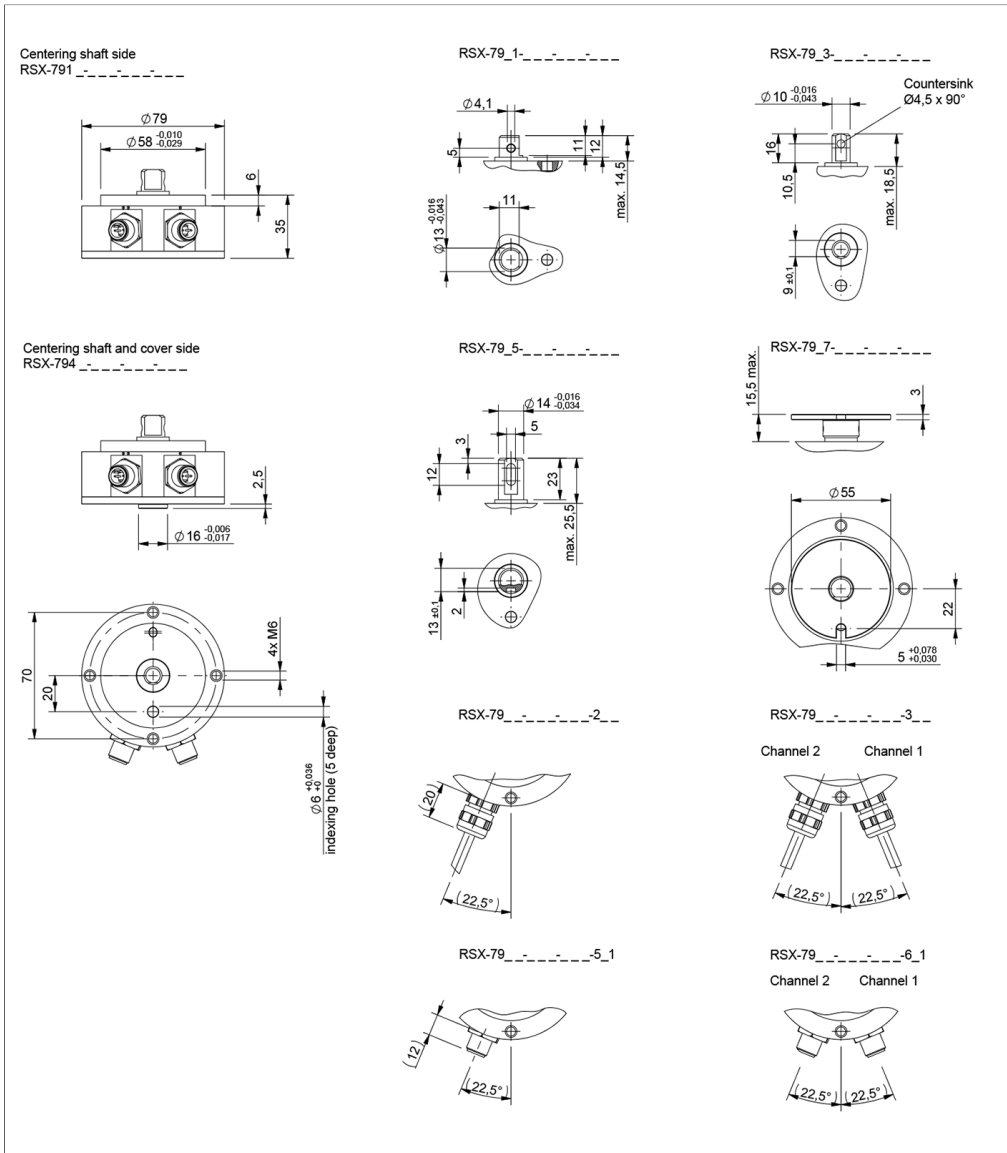

When the flattening of the shaft points towards the indexing hole, the sensor is near the electrical center position.

## Technical Data

<b>Type</b>	<b>RSX-79_ _ _ _ _38_ _ _ _</b> <b>Analog current</b>
Output signal	4 ... 20 mA
Burden	@Ub > 13 V: ≤ 500 Ω, @Ub ≤ 13 V: ≤ 250 Ω
Number of channels	1 / 2
Diagnosis	activated (in case of error, output signal is outside of the plausible signal range)
Update rate	typ. 3.4 kHz
Measuring range	60°, 120°, 180°, 240°, 300°, 360°
Absolute linearity	Measuring range < 90°: ±2 %FS, Measuring range ≥ 90°: ±1 %FS
Interlinearity	Measuring range < 90°: ±4 %FS, Measuring range ≥ 90°: ±2 %FS
Resolution	12 bits
Repeatability	typ. ≤ ±0.1°
Hysteresis	typ. < ±0.1° Only measuring range 360°: typ. < 0.25° (lower hysteresis on request)
Temperature error	Measuring range 30 ... 170°: typ. ±1.2 %FS, Measuring range ≥ 180°: typ. ±0.6 %FS
Supply voltage Ub	12/24 VDC (8 ... 34 VDC)
Current consumption w/o load	typ. 12 mA per channel
Polarity protection	yes (supply lines and outputs)
Short circuit protection	yes (vs. GND and supply voltage Ub)
Insulation resistance (500 VDC)	≥ 10 MΩ
<b>Environmental Data</b>	
Max. operational speed	50 rpm
Vibration IEC 60068-2-6	20 g, 5 ... 2000 Hz, Amax = 0.75 mm
Shock IEC 60068-2-27	50 g, 6 ms
Protection class ISO 20653	IP67 / IP69K (connector M12: IP67)
Operating temperature	-40 ... +85°C
Life	> 100 Mio. movements
Functional safety	Suitable for safety-related applications according to ISO 13849 after customer validation. Further safety data ( DCavg...) and support for functional safety are available on request.
MTTF (IEC 60050)	741 years (one-channel), 742 years (partly redundant, per channel) or 742 years (fully redundant, per channel)
MTTFd (EN ISO 13849-1 parts count method, w/o load)	1074 years (one-channel), 1076 years (partly redundant, per channel) or 1076 years (fully redundant, per channel)
Traceability	Serial number on type labeling: production batch of the sensor assembly and relevant sensor components
<b>EMC Compatibility</b>	
ISO 10605 ESD (Component)	8 kV
ISO 11452-2 Radiated HF-fields	100 V/m
ISO 11452-4 BCI (Bulk current injection)	100 mA
CISPR 25 Radiated emission	Level acc. ISO 13766-1
ISO 7637-2 Pulses on supply lines	(1, 2a, 2b, 3a, 3b) Level 3
ISO 7637-3 Pulses on output lines	Level 4
ISO 16750 Pulses on supply lines	Starting profile Level 4 @12 V / Level 2 @24 V, Load dump A +101 V @12 V / +202 V @24 V
ISO 13766-1/-2 Construction machinery	

FS = Full scale: Signal span according to electrical measuring range

**Connection Assignment**

Signal	Connector code 5__	Cable code 2__	Connector code 5__	Cable code 2__	2x Connector code 6__	2x Cable code 3__
	One-channel	One-channel	Partly redundant	Partly redundant	Fully redundant	Fully redundant
Supply voltage Ub 1	Pin 1	GN	Pin 1	GN	Channel 1 / Pin 1	Channel 1 / GN
GND 1	Pin 3	BN	Pin 3	BN	Channel 1 / Pin 3	Channel 1 / BN
Signal output 1	Pin 2	WH	Pin 2	WH	Channel 1 / Pin 2	Channel 1 / WH
Signal output 2	-	-	Pin 4	YE	Channel 2 / Pin 4	Channel 2 / YE
Supply voltage Ub 2	-	-	-	-	Channel 2 / Pin 1	Channel 2 / GN
GND 2	-	-	-	-	Channel 2 / Pin 3	Channel 2 / BN
Not assigned	Pin 4	YE	-	-	Channel 1 / Pin 4 Channel 2 / Pin 2	Channel 1 / YE Channel 2 / WH

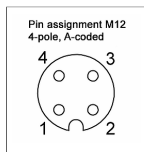

**Technical Data  
Output  
Characteristics**

Output characteristic

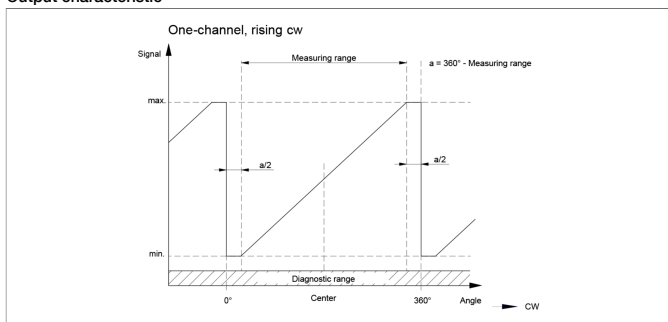

Output characteristic

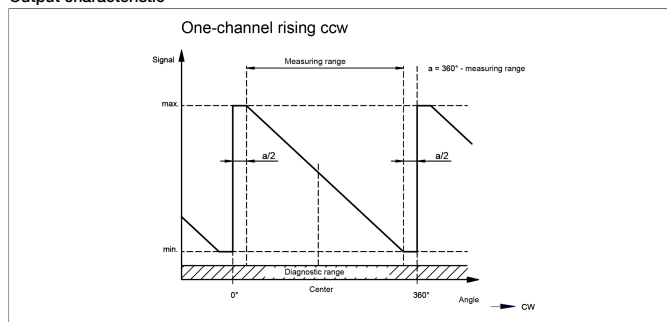

Output characteristic

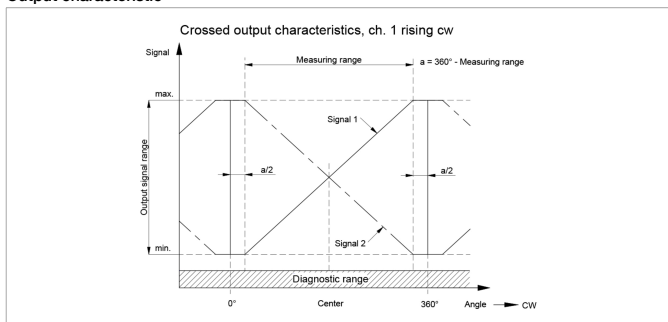

Output characteristic

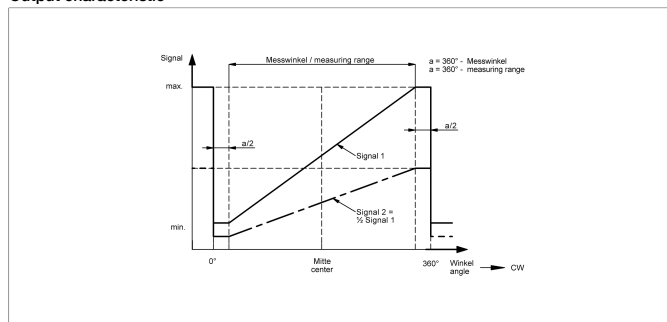

Output characteristic

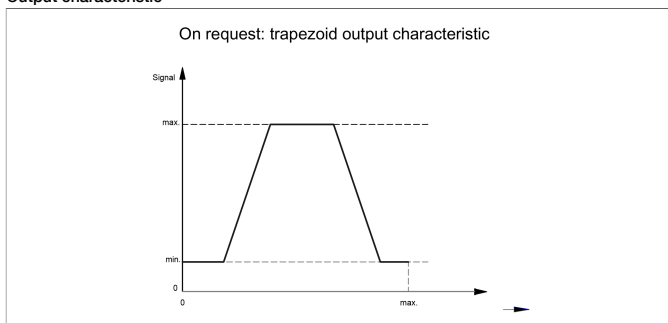

Output characteristic

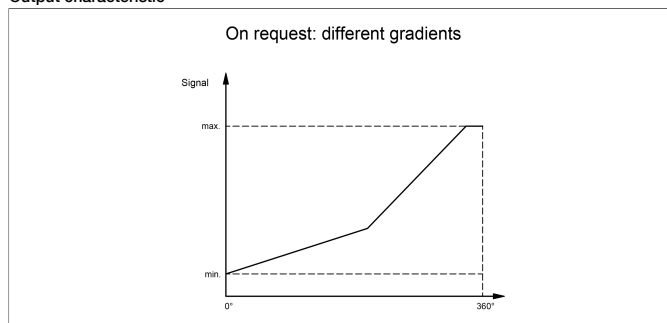

Output characteristic

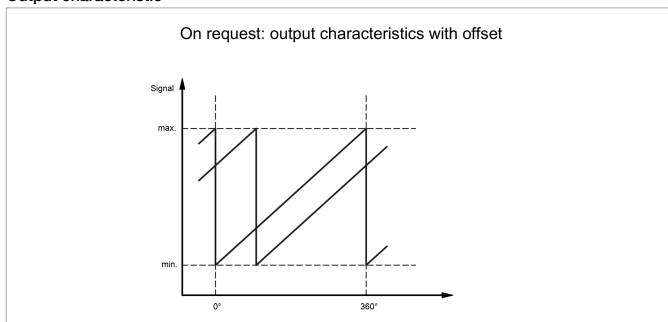

Output characteristic

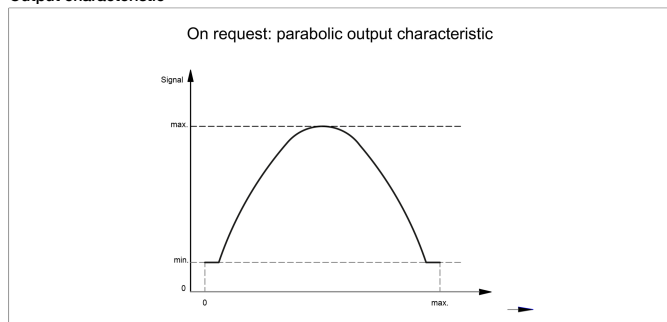

## Sensor Mounting

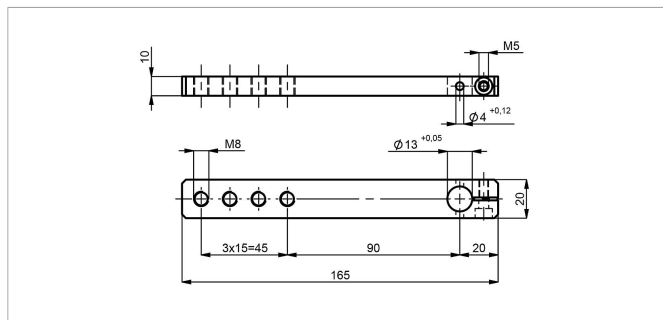
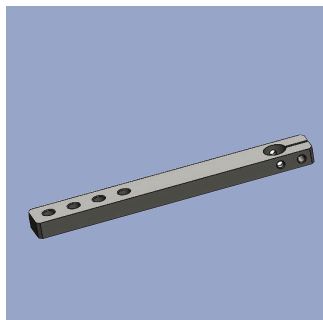

### Z-IPX-M01

Lever arm 165 x 20 mm for pivot head drive.  
Mounted to shaft D = 13 mm with locking pin and screw (both included in delivery)

Material Aluminium, anodized

P/N	Type
400105430	Z-IPX-M01

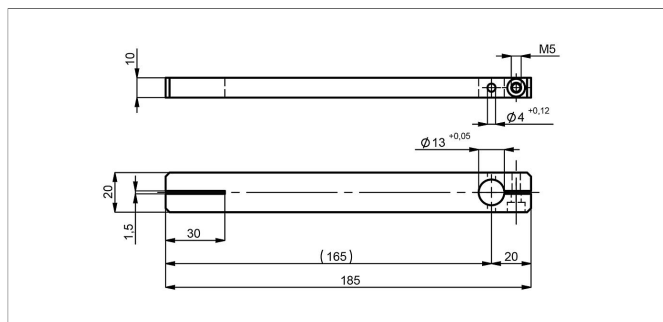
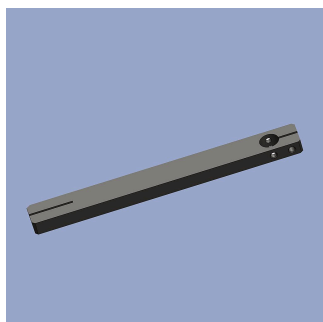

### Z-IPX-M11

Lever arm 185 x 20 mm for lever arm drive, clamp connection on dimension 20 mm.  
Mounted to shaft D = 13 mm with locking pin and screw (both included in delivery)

Material Aluminium, anodized

P/N	Type
400105431	Z-IPX-M11

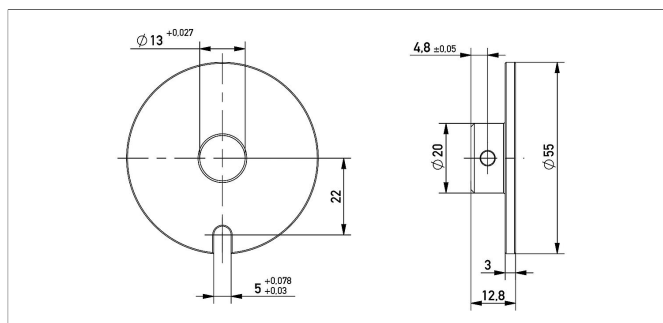
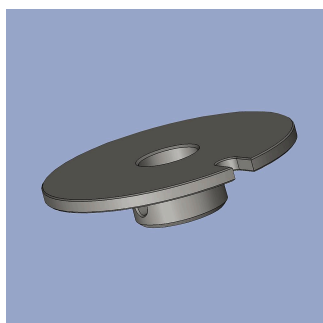

### Z-IPX-M21

Driving plate D = 55 mm for lateral shaft drive with locking pin. Mounted to shaft D = 13 mm with locking pin (included in delivery)

Material Aluminium, anodized

P/N	Type
400105433	Z-IPX-M21

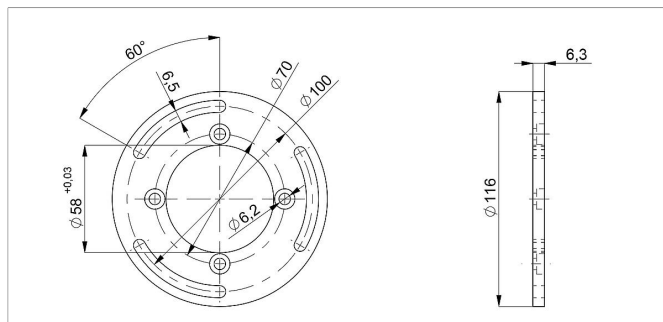
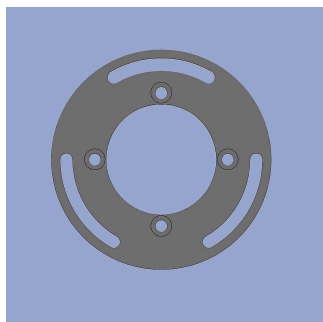

### Z-IPX-M31

Mounting plate for adjustable mounting on screw-hole circle 100 mm. Assembly material (4 x cylinder head screws) included in delivery

Material Aluminium, anodized

P/N	Type
400105432	Z-IPX-M31

## Connector System M12

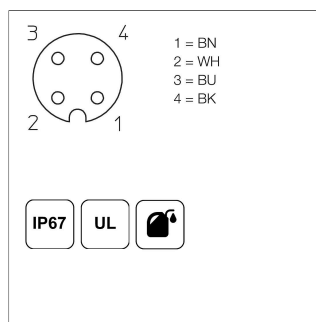
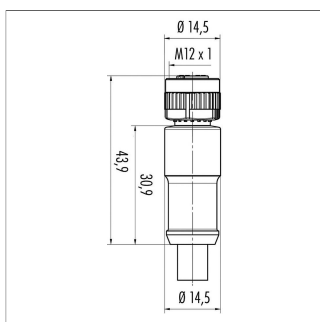

**EEM-33-35/36/37**  
M12x1 Mating female connector, 4-pin, straight, A-coded, with molded cable, not shielded, IP67, open ended  
Plug housing PA  
Cable sheath PUR,  $\varnothing$  = max. 6 mm, -40 ... +85°C (fixed)  
Lead wires PP, 0.34 mm<sup>2</sup>

P/N	Type	Length
400056135	EEM-33-35	2 m
400056136	EEM-33-36	5 m
400056137	EEM-33-37	10 m

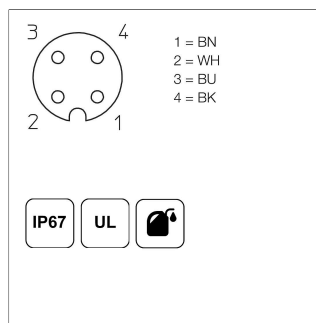
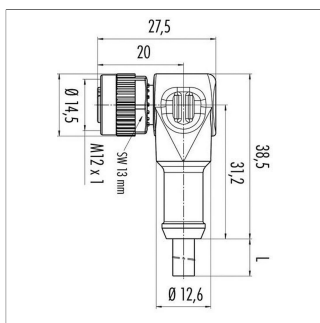
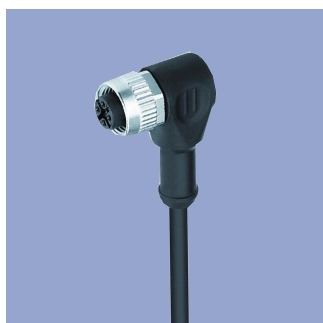

**EEM-33-38/39/40**  
M12x1 Mating female connector, 4-pin, angled, A-coded, with molded cable, not shielded, IP67, open ended  
Plug housing PA  
Cable sheath PUR,  $\varnothing$  = max. 6 mm, -40 ... +85°C (fixed)  
Lead wires PP, 0.34 mm<sup>2</sup>

P/N	Type	Length
400056138	EEM-33-38	2 m
400056139	EEM-33-39	5 m
400056140	EEM-33-40	10 m

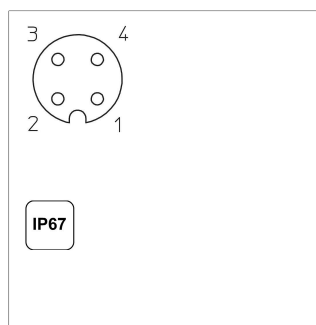
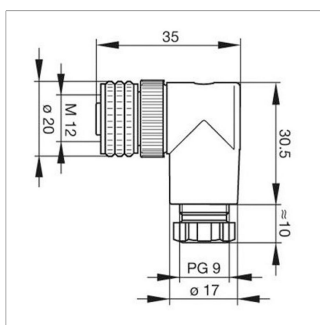

**EEM-33-89**  
M12x1 Mating female connector, 4-pin, angled, A-coded, with coupling nut, screw termination, IP67, not shieldable  
Operating temp. -25 ... +90°C  
Plug housing PBT  
For wire gauge 6 ... 8 mm, max. 0.75 mm<sup>2</sup>

P/N	Type
400005634	EEM-33-89

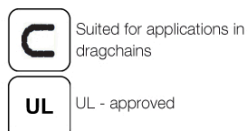
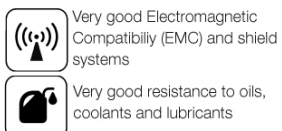
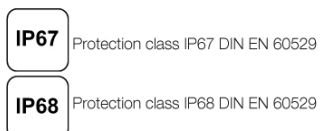

Novotechnik  
Messwertaufnehmer OHG  
P.O.Box 4220  
73745 Ostfildern (Germany)  
Horbstrasse 12  
73760 Ostfildern (Germany)  
Phone +49 711 4489-0  
Fax +49 711 4489-118  
info@novotechnik.de  
www.novotechnik.de



© Jun 30, 2025

The specifications contained in our datasheets are intended solely for informational purposes. The documented specification values are based on ideal operational and environmental conditions and can vary significantly depending on the actual customer application. Using our products at or close to one or more of the specified performance ranges can lead to limitations regarding other performance parameters. It is therefore necessary that the end user verifies relevant performance parameters in the intended application. We reserve the right to change product specifications without notice.