

**NOVOHALL
Rotary Sensor
Non-contacting**

RSC-2800

Voltage

Industrial

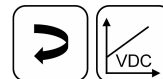

Special Features

- Non-contacting, magnetic technology
- Measuring range up to 360°
- Available with push-on coupling or marked shaft
- Simple mounting
- Protection class IP54, IP65, IP67
- Long life
- Very small hysteresis
- High resolution 12 bits
- Linearity <math>< \pm 0.5\% </math>
- Other configurations see separate data sheets

Applications

- Manufacturing Engineering (textile machinery, packaging machinery, sheet metal and wire machinery)
- Automation technology
- Medical Engineering

The RSC-2800 sensor utilizes a contactless magnetic measurement technology to determine the measured angle. Unlike conventional Hall sensors, the orientation of the magnetic field is measured. The position information corresponding to the angular position is transmitted via a variety of analog and digital interfaces (see separate data sheets).

The housing is made of a special high grade temperature-resistant plastic material. Elongated slots allow simplicity in mounting together with ease of mechanical adjustment.

Three shaft options are available, including a push-on coupling option that ensures fast and simple installation.

Description

Material	Housing: high grade, temperature resistant plastic PPS-GF40/SF50 Shaft: stainless steel, X8CrNiS18-9 1.4305
Mounting	With 2 screws M4 and washers
Max. fastening torque of mounting screws	max. 180 Ncm
Bearing	Sintered bronze bushing
Electrical connection	Cable 4x 0.5 mm ² (AWG 20), TPE, shielded / Connector M12x1, A-coded with cable L = 0.15 m

Mechanical Data

Dimensions	See dimension drawing
Mechanical travel	continuous
Permitted shaft load static or dynamic	20 N (axial / radial)
Torque	0.15 Ncm (IP54), 0.5 Ncm (IP65), 1.0 Ncm (IP67)
Weight	approx. 50 g

Ordering Specifications

Ordering Specifications

Preferred types printed in bold

- Delivery time up to 25 pcs. within 10 working days EXW
- Best low-volume pricing

Supply voltage Ub

1: Ub = 24 VDC

Interface parameters

1: 0.1 ... 10 VDC

Output characteristic

- 1: Rising output characteristic cw
 2: Rising output characteristic ccw
 Other output characteristics on request

Electrical connection

- 201: Cable, 4-pole, shielded, L = 0.5 m
202: Cable, 4-pole, shielded, L = 1 m
206: Cable, 4-pole, shielded, L = 3 m
 210: Cable, 4-pole, shielded, L = 5 m
 220: Cable, 4-pole, shielded, L = 10 m
501: Conector M12x1, 4-pin, with cable, shielded, L = 0.15 m
 Cable versions and assembled connectors on request

R S C - 2 8 3 2 - 6 3 6 - 1 1 1 - 2 0 2

Series

Measuring range

- 03: Angle 0° ... 30° min.
 ...
06, 12, 18, 24, 36
 ...
 36: Angle 0° ... 360° max.
 Other angles on request

Number of channels

6: One-channel version (1 x supply voltage Ub / 1 x output)

Mechanical version

- 2801: 6 mm shaft with marking, IP54*
 2831: 6 mm shaft with marking, IP65*
 2861: 6 mm shaft with marking, IP67*
 2802: 6 mm shaft with flattening, IP54
2832: 6 mm shaft with flattening, IP65
 2862: 6 mm shaft with flattening, IP67
 2821: push-on coupling, IP54
2841: push-on coupling, IP65
 2871: push-on coupling, IP67
 Other shaft configurations on request

* Not recommended for new designs

Drawing

CAD data see
www.novotechnik.de/en/download/cad-
data/

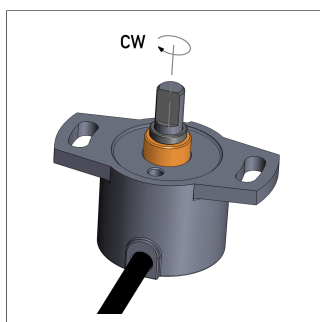
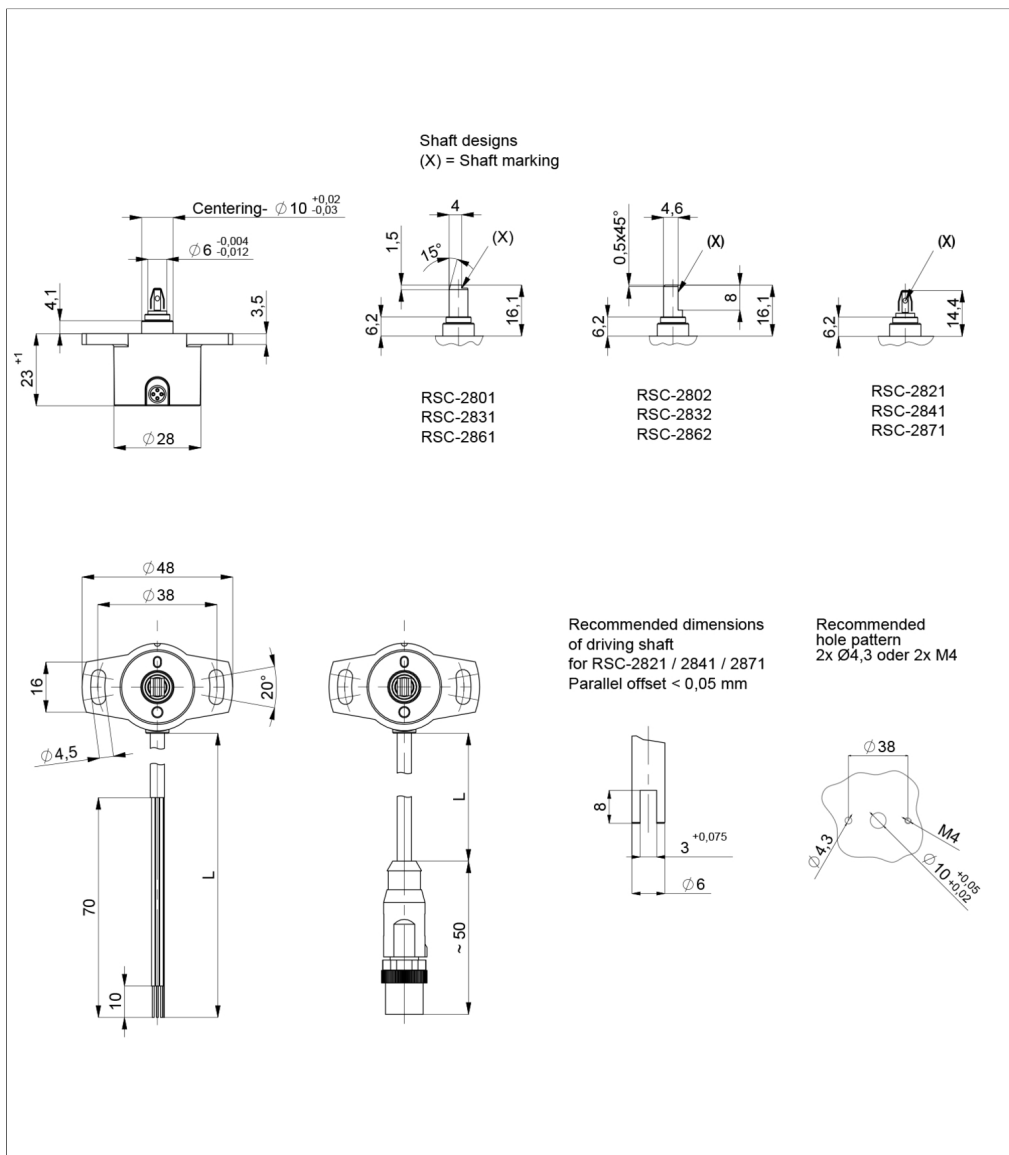

When the marking of the shaft is pointing towards the electrical outlet, the sensor output is near the electrical center position.

Technical Data

Type	RSC-28 _ _ _ _ _11_ _ _ _
Output signal	0.1 ... 10 V
Load	≥ 10 kΩ
Number of channels	1
Update rate	typ. 5 kHz
Measuring range	0 ... 30° up to 0 ... 360° in 10°-steps
Independent linearity	≤ ±0.5 %FS
Resolution	12 bits
Repeatability	≤ ±0.1°
Hysteresis	≤ ±0.1°
Temperature error	Measuring range 30 ... 170°: ≤ ±0.94 %FS, Measuring range ≥ 180°: ≤ ±0.5 %FS
Supply voltage Ub	24 VDC (18 ... 30 VDC)
Current consumption w/o load	typ. 15 mA (typ. 8 mA on request)
Polarity protection	yes (supply lines)
Short circuit protection	yes (vs. GND and supply voltage Ub)
Insulation resistance (500 VDC)	≥ 10 MΩ
Environmental Data	
Max. operational speed	800 rpm
Vibration IEC 60068-2-6	20 g, 5 ... 2000 Hz, Amax = 0.75 mm
Shock IEC 60068-2-27	50 g, 6 ms
Protection class DIN EN 60529	IP54 / IP65 / IP67
Operating temperature	-40 ... +85°C -25 ... +85°C (connector M12)
Life	> 50 Mio. movements (mechanically)
Functional safety	If you need assistance in using our products in safety-related systems, please contact us
MTTF (IEC 60050)	1446 years
EMC Compatibility	
EN 61000-4-2 ESD (contact/air discharge)	4 kV, 8 kV
EN 61000-4-3 Electromagnetic fields (RFI)	10 V/m
EN 61000-4-4 Fast transients (burst)	1 kV
EN 61000-4-6 Cond. disturbances (HF fields)	10 V eff.
EN 61000-4-8 Magnetic fields	3 A/m
EN 55011 Noise radiation	Class B

FS = Full scale: Signal span according to electrical measuring range

Connection Assignment

Signal	Cable code 2_ _	Connector code 5_ _
Supply voltage Ub	GN	Pin 1
GND	BN	Pin 3
Signal output	WH	Pin 2
Do not connect / not assigned	YE	Pin 4
Connect cable shielding to GND		

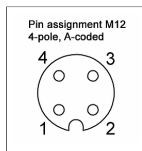

**Technical Data
Output
Characteristics**

Output characteristic

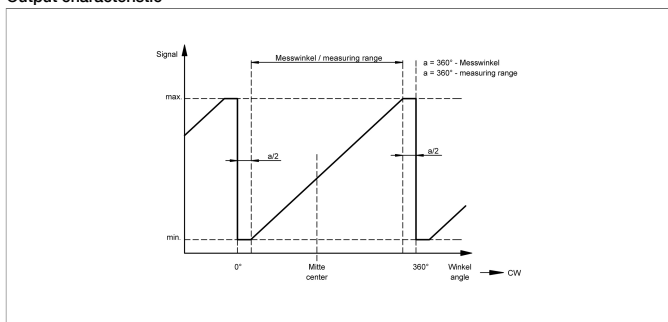

Output characteristic

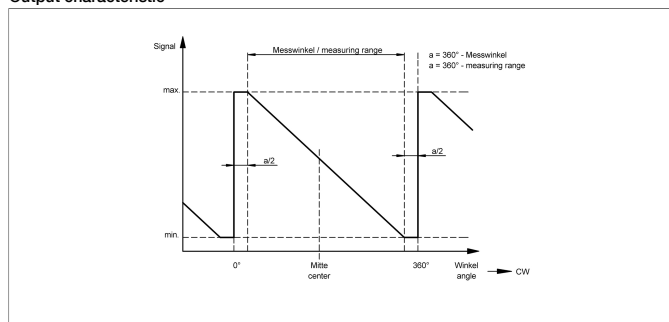

Output characteristic

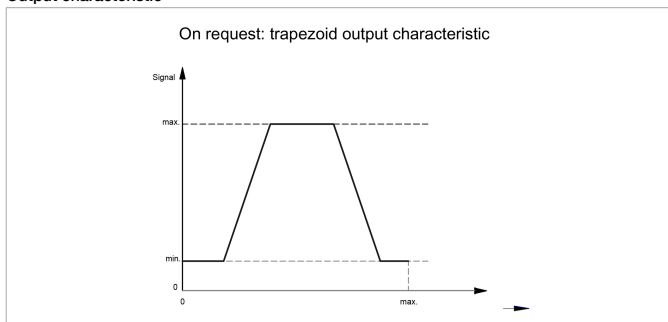

Output characteristic

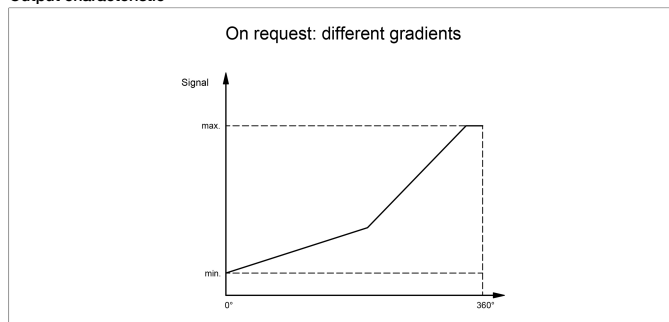

Output characteristic

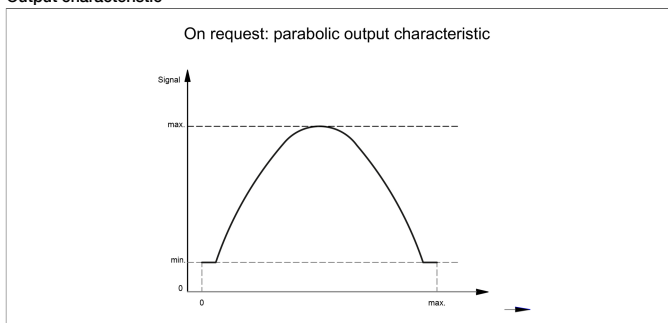

Sensor Mounting

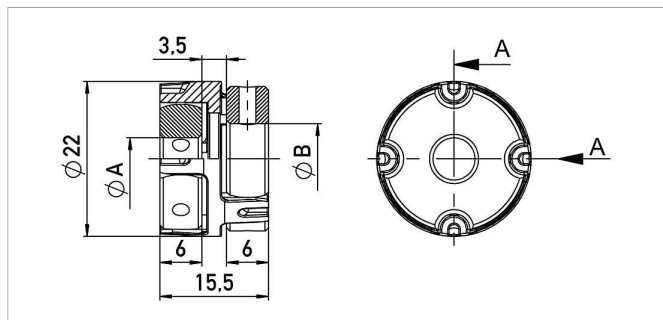
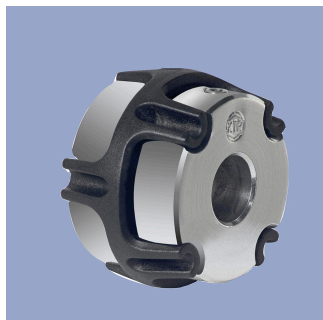

Z-106-G_

Backlash-free, double cardanic shaft coupling for Ø6 mm to Ø6 mm, Ø6.35 mm or Ø10 mm, mounting via 2 threaded pins with internal hexagon

Material Aluminium, PEEK

Operating temp. -40 ... +160°C

Transferable torque ≤ 1 Nm

torque

Displacement rad. ≤ 0.1 mm, angl. ≤ 0.45°

P/N	Type	ØA / ØB [mm]
400103910	Z-106-G-6	6 / 6
400103912	Z-106-G-6,35	6 / 6.35
400103913	Z-106-G-10	6 / 10

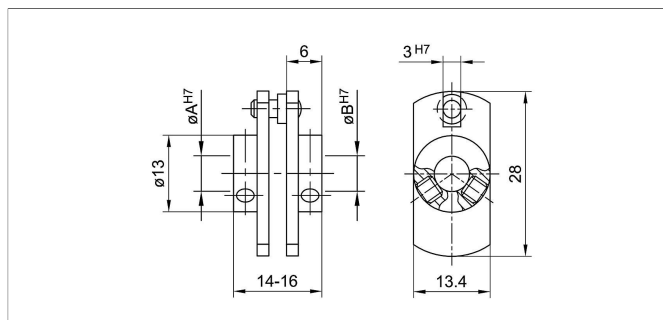
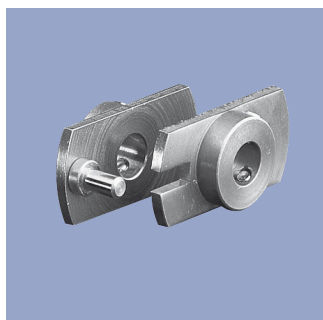

Z-104-G-6

Fork coupling with low backlash for Ø6 mm.

Mounting with 2 cylinder head screws M3 with internal hexagon.

Angle screwdriver DIN 911 AF 1.5 included in delivery.

Material Stainless Steel, driving pin polished

Displacement ≤ 1 mm

P/N	Type	ØA / ØB [mm]
400005690	Z-104-G-6	6 / 6

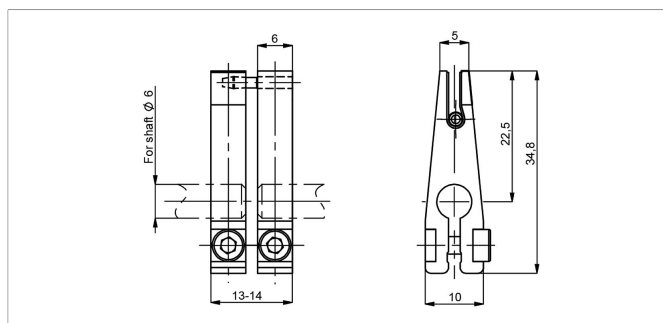
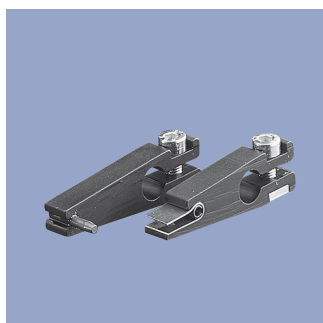

Z-105-G-6

Backlash-free fork coupling for Ø6 mm. Mounting with 1 cylinder head screw M3 with internal hexagon.

Angle screwdriver DIN 911 AF 2.5 included in delivery.

Material Aluminium, anodized (black)
Driving pin and spring hardened

Transferable torque ≤ 5 Ncm

torque

Displacement ≤ 1 mm

P/N	Type
400005691	Z-105-G-6

Connector System M12

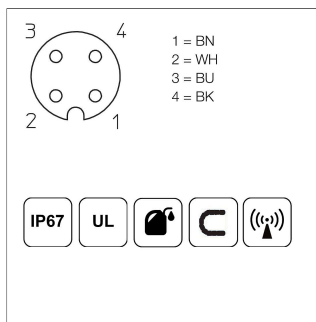
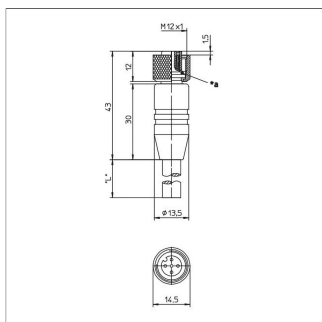
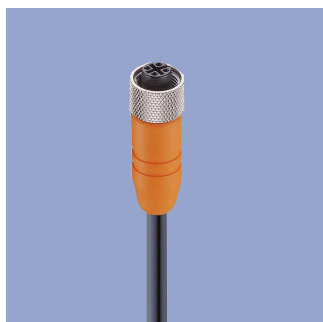

EEM-33-32/62/97
M12x1 Mating female connector, 4-pin, straight, A-coded, with molded cable, shielded, IP67, open ended

Plug housing PA
Cable sheath PUR, Ø = max. 6 mm, -25 ... +80°C (moved), -50 ... +80°C (fixed)

Lead wires PP, 0.34 mm²

P/N	Type	Length
400005600	EEM-33-32	2 m
400005609	EEM-33-62	5 m
400005650	EEM-33-97	10 m

IP67 Protection class IP67 DIN EN 60529

IP68 Protection class IP68 DIN EN 60529

EMC Very good Electromagnetic Compatibility (EMC) and shield systems

Oil Very good resistance to oils, coolants and lubricants

C Suited for applications in dragchains

UL UL - approved

CAN CAN-Bus

Signal Processing

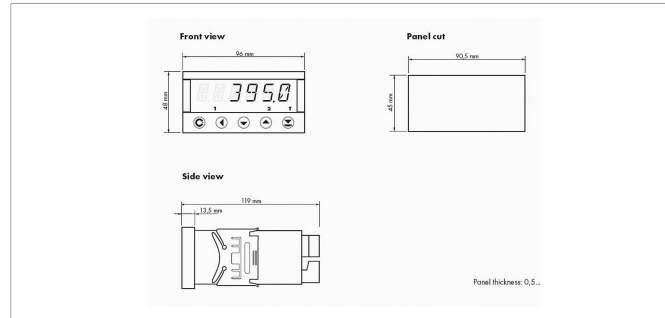

MAP-4000

Multifunctional measuring device with digital display for direct connection of potentiometric and normalized signals.

- Supply voltage 10...30 VDC, 80...250 VDC or AC
- High accuracy up to 0.1%
- Adjustable supply voltage for sensors 5...24 V
- Temperature coefficient 100 ppm/K
- Optional RS 232, RS 485, analog output, limited switch
- Complete data see separate data sheet

Connecting Options on request



- M12 connector**
- Customized lengths
 - 3-, 4-, 6- and 8-pole versions
 - Protection class IP68
 - Ordering codes of standard versions see ordering specifications

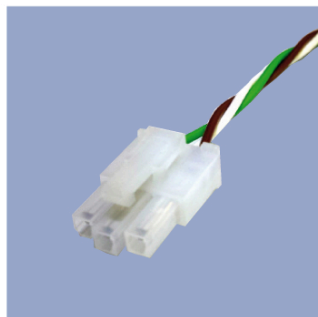

- Molex Mini Fit jr.**
- Customized length and lead wires
 - 3-, 4- and 6-pole versions
 - On request



- Tyco AMP Super Seal**
- Pin- and bushing housing
 - Customized lengths
 - 3-, 4- and 6-pole versions
 - Protection class IP67
 - On request



- Molex Mini Fit jr.**
- Customized length and lead wires
 - 3-, 4- and 6-pole versions
 - On request



- Deutsch DTM 04**
- Pin- and bushing housing
 - Customized lengths
 - 3-, 4- and 6-pole versions
 - Protection class IP67
 - On request



- ITT Cannon Sure Seal connector**
- Customized lengths
 - 3-, 4- and 6-pole versions
 - Protection class IP67
 - On request

Novotechnik
Messwertaufnehmer OHG
P.O.Box 4220
73745 Ostfildern (Germany)
Horbstrasse 12
73760 Ostfildern (Germany)
Phone +49 711 4489-0
Fax +49 711 4489-118
info@novotechnik.de
www.novotechnik.de



© Feb 20, 2025

The specifications contained in our datasheets are intended solely for informational purposes. The documented specification values are based on ideal operational and environmental conditions and can vary significantly depending on the actual customer application. Using our products at or close to one or more of the specified performance ranges can lead to limitations regarding other performance parameters. It is therefore necessary that the end user verifies relevant performance parameters in the intended application. We reserve the right to change product specifications without notice.