

**NOVOTURN
Multi-turn Sensor
Non-contacting**

RSM-2800
Voltage
Industrial

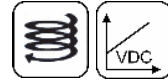

Special Features

- Non-contacting, magnetic
- Long life
- Measuring range 720° up to 5760° in 360°-steps (2 to 16 turns)
- True-Power-On system: counts turns even when not powered. Patented non-volatile technology does not require gears or batteries
- Available with push-on coupling or marked shaft
- Easy mounting
- Protection class IP54 up to IP67
- One or multi-channel versions
- Resolution 16 bits
- Linearity up to $\pm 0,03\%$
- Other configurations see separate data sheets

Applications

- Mechanical engineering
- Mobile machinery
- Driveline or steering systems
- Wire-actuated encoders
- Gate drives
- Motor sports

Multi-turn sensors that use the GMR technology (giant magneto resistance), provide absolute position values, do not require any reference signals and need no power supply or buffer battery for detecting the revolutions. The fact that rotations are detected even unpowered and the sensor does not lose its position information during a power failure, makes the RSM-2800 with its diameter of only 28 mm an extremely compact real True-Power-On rotary sensor.

The sensor operates magnetically and thus contactless allowing an extremely long life.

The sensor is able to detect angular positions over 2 to 16 revolutions with a high resolution of 16 bits.

Description

Material	Housing: high grade, temperature resistant plastic PPS-GF40/SF50 Shaft: stainless steel, X8CrNiS18-9 1.4305
Mounting	With 2 screws M4 and washers
Fastening torque of mounting	max. 180 Ncm
Bearing	Sintered bronze bushing
Electrical connection	Cable 4x 0.5 mm ² (AWG 20), TPE, shielded / Connector M12x1, A-coded with cable L = 0.15 m

Mechanical Data

Dimensions	See dimension drawing
Mechanical travel	continuous
Permitted shaft load static or dynamic	20 N (axial / radial)
Torque	0.15 Ncm (IP54), 0.5 Ncm (IP65), 1.0 Ncm (IP67)
Weight	approx. 50 g

Ordering Specifications

Ordering Specifications

Preferred types printed in bold

- Delivery time up to 25 pcs. within 10 working days EXW
- Best low-volume pricing

Supply voltage U_b

1: $U_b = 24$ VDC

Interface parameters

1: 0.1 ... 10 VDC

Output characteristic

- 1: **Rising characteristic cw**
 - 2: Rising characteristic ccw
 - 3: **Crossed outputs, channel 1 rising cw**
- Other output characteristics on request

Electrical connection

- 201: Cable, 4-pole, shielded, L = 0.5 m
 - 202: Cable, 4-pole, shielded, L = 1 m**
 - 206: Cable, 4-pole, shielded, L = 3 m**
 - 210: Cable, 4-pole, shielded, L = 5 m
 - 220: Cable, 4-pole, shielded, L = 10 m
 - 501: Conector M12x1, 4-pin, with cable, shielded, L = 0.15 m**
- Cable versions and assembled connectors on request

R S M - 2 8 3 2 - 0 1 0 - 1 1 1 - 2 0 2

Series

Number of turns for output characteristic

002 ... 016: 2 up to 16 turns
 Increment 1 turn, X turns correspond to a measuring angle of $X \cdot 360^\circ$
003, 006, 010, 016: 3, 6, 10, 16 turns
 Other measuring angles on request

Mechanical version

- 2801: 6 mm shaft with marking, IP54*
 - 2831: 6 mm shaft with marking, IP65*
 - 2861: 6 mm shaft with marking, IP67*
 - 2802: 6 mm shaft with flattening, IP54
 - 2832: 6 mm shaft with flattening, IP65**
 - 2862: 6 mm shaft with flattening, IP67
 - 2821: push-on coupling, IP54
 - 2841: push-on coupling, IP65**
 - 2871: push-on coupling, IP67
- Other shaft configurations on request
 * Not recommended for new designs

Drawing

CAD data see
www.novotechnik.de/en/download/cad-data/

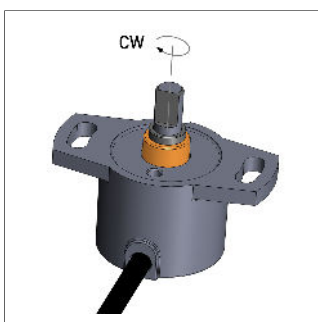
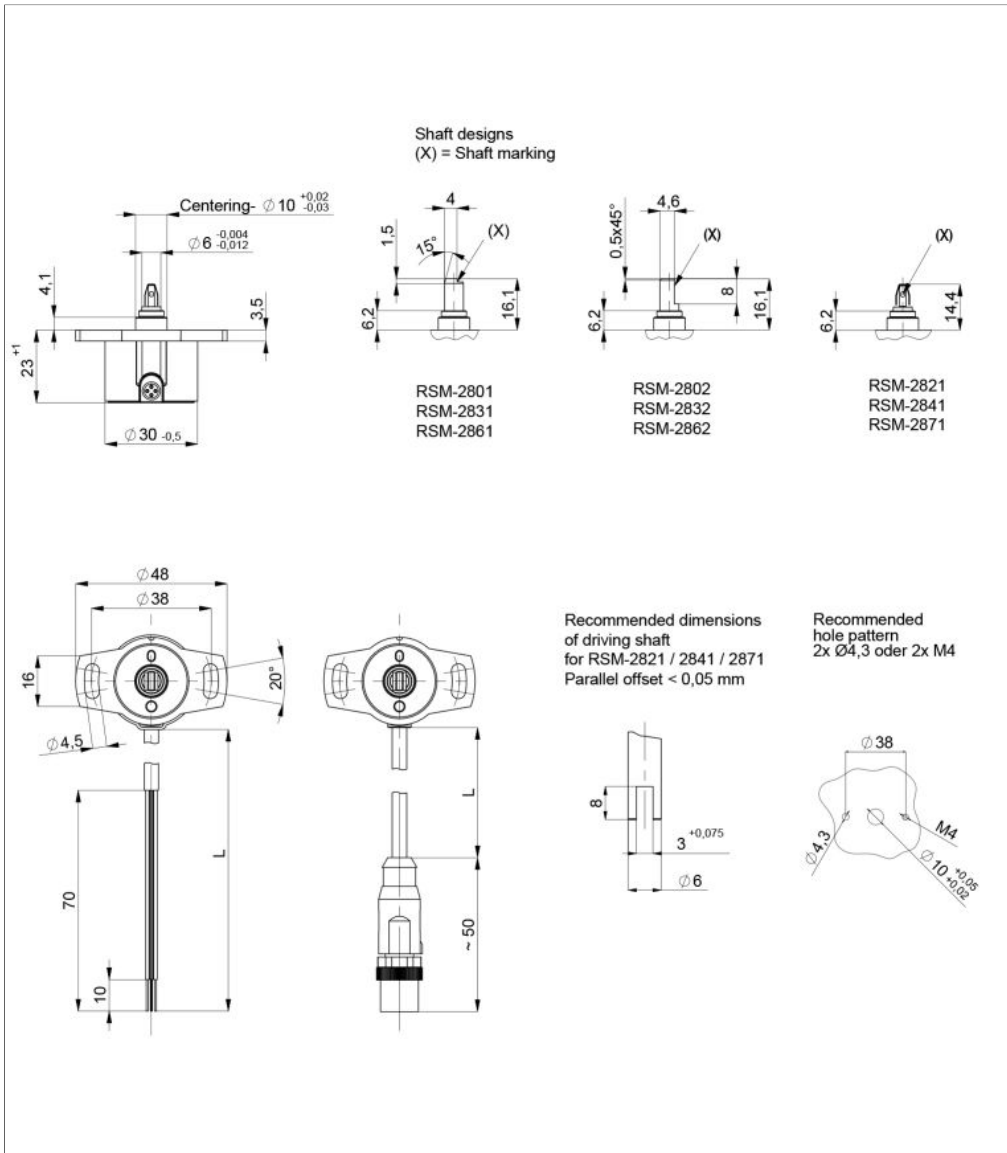

When the marking of the shaft is pointing towards the electrical outlet, the sensor output is located on an integer turn position.

Technical Data

Type	RSM-28 _ _ _ _ _11_ _ _ _
Output signal	0.1 ... 10 V
Load	≥ 10 kΩ
Number of channels	1 / 2
Start-up time	typ. 10 ms
Response time	max. 2 ms
Measuring range	0 ... 720° up to 0 ... 5760° in 360°-steps
Independent linearity	2 turns: typ. ≤ ±0.25 %FS, max. ≤ ±0.35 %FS 3 turns: typ. ≤ ±0.167 %FS, max. ≤ ±0.267 %FS 6 turns: typ. ≤ ±0.083 %FS, max. ≤ ±0.183 %FS 10 turns: typ. ≤ ±0.05 %FS, max. ≤ ±0.15 %FS 16 turns: typ. ≤ ±0.031 %FS, max. ≤ ±0.131 %FS
Resolution	16 bits
Repeatability	≤ ±0.5°
Hysteresis	≤ ±1°
Temperature error	±0.31 %FS
Supply voltage Ub	24 VDC (18 ... 30 VDC)
Current consumption w/o load	typ. 30 mA
Polarity protection	yes (supply lines and outputs)
Short circuit protection	yes (vs. GND and supply voltage Ub)
Insulation resistance (500 VDC)	≥ 10 MΩ
Environmental Data	
Max. operational speed	800 rpm
Vibration IEC 60068-2-6	20 g, 5 ... 2000 Hz, Amax = 0.75 mm
Shock IEC 60068-2-27	50 g, 6 ms
Protection class DIN EN 60529	IP54 / IP65 / IP67
Operating temperature	-40 ... +85°C -25 ... +85°C (connector M12)
Insensitivity to magnetic DC fields	< 15 mT
Life	> 50 Mio. movements (mechanically)
MTTF (IEC 60050)	184 years (per channel)
EMC Compatibility	
EN 61000-4-2 ESD (contact/air discharge)	4 kV, 8 kV
EN 61000-4-3 Electromagnetic fields (RFI)	10 V/m
EN 61000-4-4 Fast transients (burst)	1 kV
EN 61000-4-6 Cond. disturbances (HF fields)	10 V eff.
EN 61000-4-8 Magnetic fields	30 A/m
EN 55011 Noise radiation	Class B

Important:

While operation, care should be taken not to rotate the sensor shaft below 0° or above 5760°. Refer to users manual.
FS = Full scale; Signal span according to electrical measuring range

Connection Assignment

Signal	Cable code 2_ _	Connector code 5_ _	Cable code 2_ _	Connector code 5_ _
	One-channel	One-channel	Two-channel	Two-channel
Supply voltage Ub	GN	Pin 1	GN	Pin 1
GND	BN	Pin 3	BN	Pin 3
Signal output 1	WH	Pin 2	WH	Pin 2
Signal output 2	-	-	YE	Pin 4
Do not connect / not assigned	YE	Pin 4	-	-
Connect cable shielding to GND				

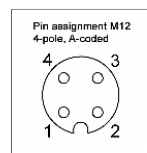

Technical Data
Output
Characteristics

Output characteristic

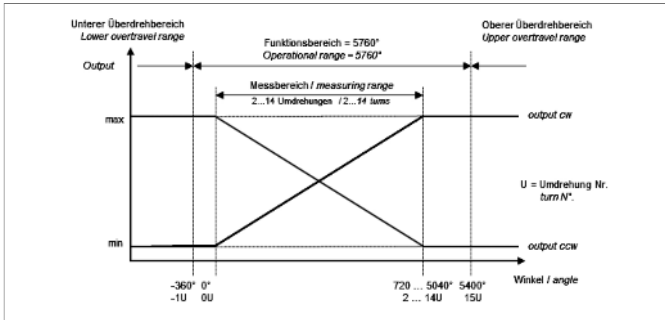

Output characteristic

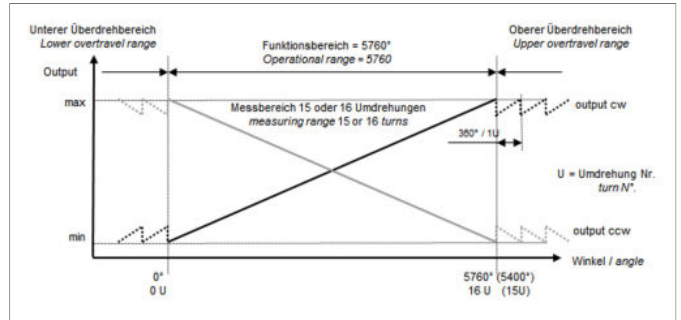

Sensor Mounting

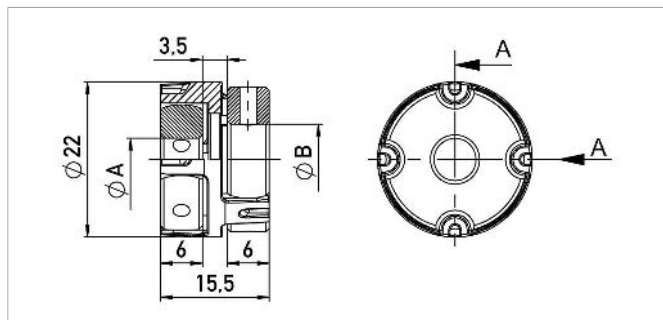

Z-106-G_
Backlash-free, double cardanic shaft coupling for Ø6 mm to Ø6 mm, Ø6.35 mm or Ø10 mm, mounting via 2 threaded pins with internal hexagon

Material Aluminium, PEEK
Operating temp. -40 ... +160°C
Transferable torque ≤ 1 Nm
Displacement rad. ≤ 0.1 mm, angl. $\leq 0.45^\circ$

P/N	Type	ØA / ØB [mm]
400103910	Z-106-G-6	6 / 6
400103912	Z-106-G-6,35	6 / 6.35
400103913	Z-106-G-10	6 / 10

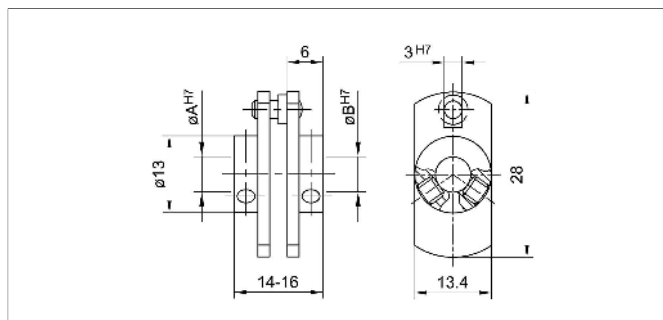
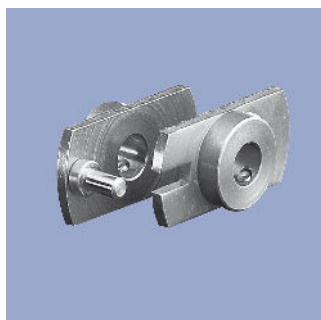

Z-104-G-6
Fork coupling with low backlash for Ø6 mm. Mounting with 2 cylinder head screws M3 with internal hexagon. Angle screwdriver DIN 911 AF 1.5 included in delivery.

Material Stainless Steel, driving pin polished
Displacement ≤ 1 mm

P/N	Type	ØA / ØB [mm]
400005690	Z-104-G-6	6 / 6

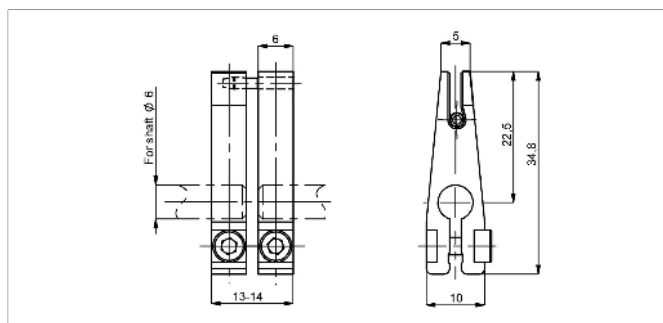
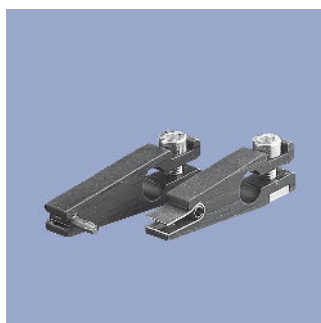

Z-105-G-6
Backlash-free fork coupling for Ø6 mm. Mounting with 1 cylinder head screw M3 with internal hexagon. Angle screwdriver DIN 911 AF 2.5 included in delivery.

Material Aluminium, anodized (black)
Driving pin and spring hardened
Transferable torque ≤ 5 Ncm
Displacement ≤ 1 mm

P/N	Type
400005691	Z-105-G-6

Connector System M12

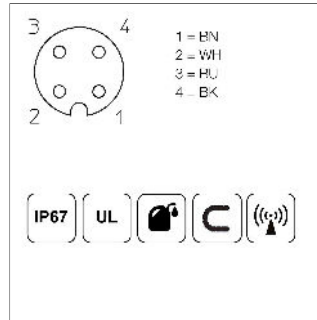
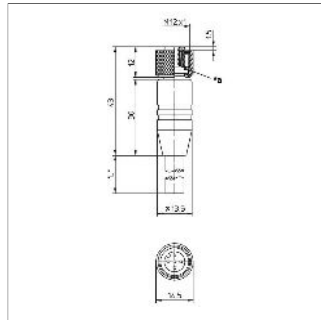
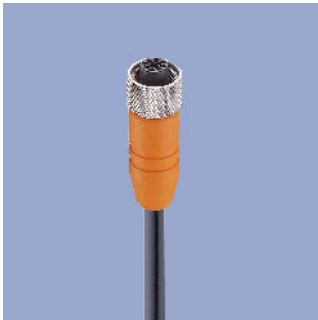

EEM-33-32/62/97

M12x1 Mating female connector, 4-pin, straight, A-coded, with molded cable, shielded, IP67, open ended

Plug housing PA
Cable sheath PUR, Ø = max. 6 mm, -25 ... +80°C (moved), -50 ... +80°C (fixed)

Lead wires PP, 0.34 mm²

P/N	Type	Length
400005600	EEM-33-32	2 m
400005609	EEM-33-62	5 m
400005650	EEM-33-97	10 m

IP67 Protection class IP67 DIN EN 60529

IP68 Protection class IP68 DIN EN 60529

 Very good Electromagnetic Compatibility (EMC) and shield systems

 Very good resistance to oils, coolants and lubricants

C Suited for applications in dragchains

UL UL - approved

 CAN-Bus

Signal Processing

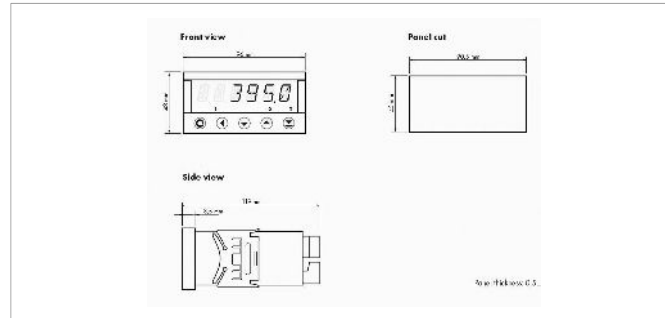

MAP-4000

Multifunctional measuring device with digital display for direct connection of potentiometric and normalized signals.

- Supply voltage 10...30 VDC, 80...250 VDC or AC
- High accuracy up to 0.1%
- Adjustable supply voltage for sensors 5...24 V
- Temperature coefficient 100 ppm/K
- Optional RS 232, RS 485, analog output, limited switch
- Complete data see separate data sheet

Connecting Options on request



- M12 connector**
- Customized lengths
 - 3-, 4-, 6- and 8-pole versions
 - Protection class IP68
 - Ordering codes of standard versions see ordering specifications

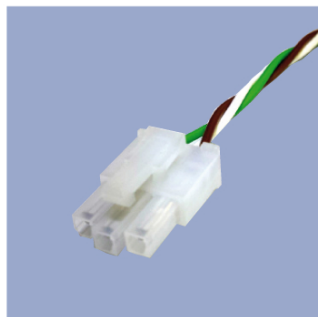

- Molex Mini Fit jr.**
- Customized length and lead wires
 - 3-, 4- and 6-pole versions
 - On request



- Tyco AMP Super Seal**
- Pin- and bushing housing
 - Customized lengths
 - 3-, 4- and 6-pole versions
 - Protection class IP67
 - On request



- Molex Mini Fit jr.**
- Customized length and lead wires
 - 3-, 4- and 6-pole versions
 - On request



- Deutsch DTM 04**
- Pin- and bushing housing
 - Customized lengths
 - 3-, 4- and 6-pole versions
 - Protection class IP67
 - On request



- ITT Cannon Sure Seal connector**
- Customized lengths
 - 3-, 4- and 6-pole versions
 - Protection class IP67
 - On request

Novotechnik
Messwertaufnehmer OHG
P.O.Box 4220
73745 Ostfildern (Germany)
Horbstrasse 12
73760 Ostfildern (Germany)
Phone +49 711 4489-0
Fax +49 711 4489-118
info@novotechnik.de
www.novotechnik.de



© Feb 20, 2025

The specifications contained in our datasheets are intended solely for informational purposes. The documented specification values are based on ideal operational and environmental conditions and can vary significantly depending on the actual customer application. Using our products at or close to one or more of the specified performance ranges can lead to limitations regarding other performance parameters. It is therefore necessary that the end user verifies relevant performance parameters in the intended application. We reserve the right to change product specifications without notice.