

Product discontinued!
Replacement requirement only on request.
Replaced by series TP1.

Transducer up to 4500 mm touchless absolute

Series TLM with Quadrature- Interface

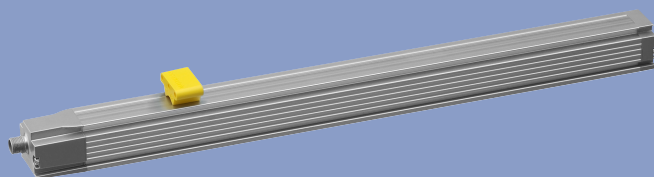

Special features

- absolute transducer, no slide arm required
- NOVOSTRICTIVE[®], touchless magnetostrictive measuring method
- non-contacting guiding with floating position marker
- unlimited mechanical life
- no velocity limit for position marker
- outstanding linearity performance up to 30 µm
- resolution up to 0.001 mm regardless of stroke length
- low temperature coefficient <20 ppm/K
- insensitive to shock and vibration
- optionally cable or plug connection
- protection class IP67 / IP68

Transducers employing the NOVOSTRICTIVE[®] touchless magnetostrictive measuring process for direct, precise and absolute measurement of linear position in control, positioning and measuring applications.

The measurement is accomplished using a passive position marker which is available in a guided or in an unguided version.

Side coupling of the position marker reduces the installation assembly dimension, prevents the pump effect of slide arms and permits stroke lengths up to 4500 mm.

The unguided version makes installation even simpler, and the wear-free operation enables unlimited mechanical life expectancy and unlimited traverse speed of the position marker.

The temperature coefficient of the transducer is extremely low thanks to the measuring principle, design and selected materials.

The high mechanical ruggedness of the transducer combined with the underlying measuring technique stands for the systems high resistance against shock and vibration. The active sensing element is encased in an aluminum housing rated to IP 67. This makes the transducer resistant to contamination, dust, moisture and oils.

Mounting is accomplished using clamps that allow precise mechanical adjustment.

A sophisticated ASIC in the transducer provides for standard absolute output signals.

The transducers series TLM with quadrature output are directly compatible with common encoder input devices. So the TLM with all its advantages like robustness, dust insensitiveness, mounting friendliness and its attractive price now is applicable for present glass or magnetic scale applications in linear positioning devices.

Output are compatible A/B/Z-signals. A and B do have a phase difference of 90° to each other. The output is optionally available as RS422 or as puhs-pull output (level 5 V or 24 V). Exceeding the maximum velocity does not result in losing increments after lowering the velocity below the specified maximum.

To make a reference drive obsolete, the sensor puts out the actual position value during the initialisation phase to the processing unit (power-on burst).

Description	
Housing	Anodized aluminium with metal end cap
Mounting	Compression clamps, longitudinally adjustable
Position marker	Floating marker (unguided), plastic Guided marker, ball coupling
Measuring technique	NOVOSTRICTIVE [®] , touchless magnetostrictive
Electrical connection	8-pin round connector, shielded, M12x1 8-conductor cable, shielded, 1 m long
Electronics	Integrated SMD with ASIC Connect cable shield to housing

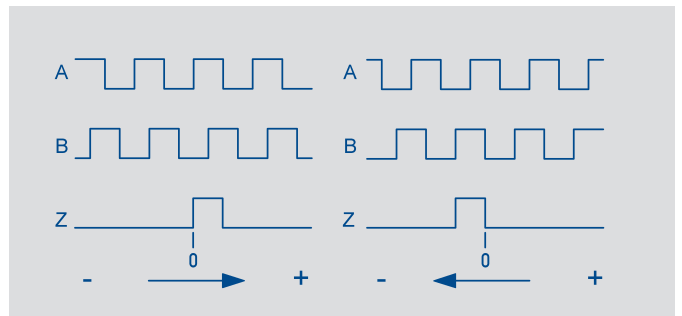
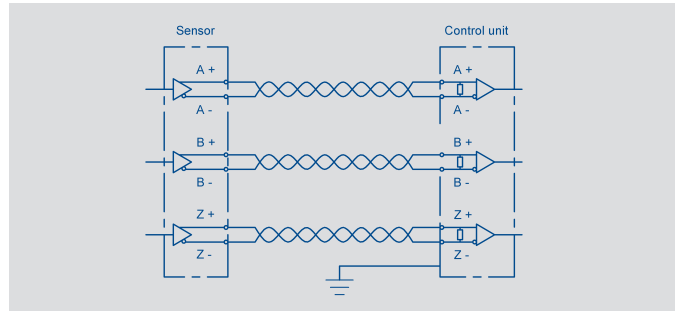
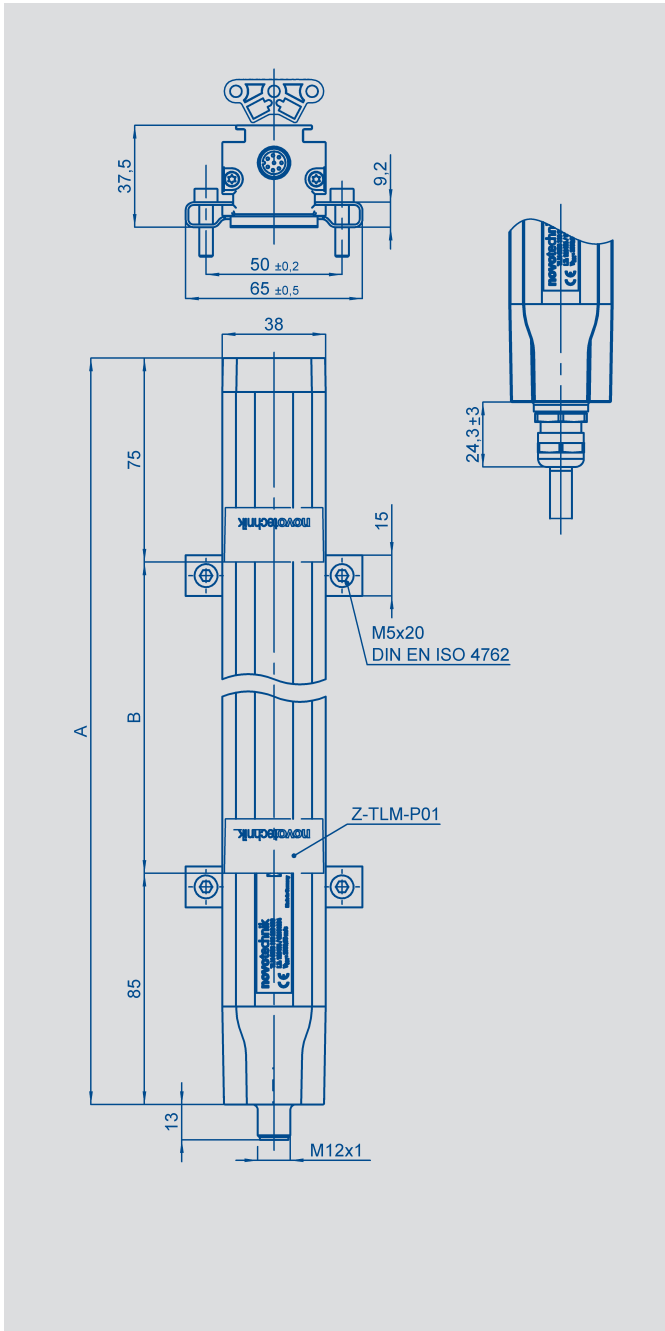

Connector Pin Code 102	Cable colours Code 201, 203, 205	Connector with cable EEM33-86, EEM33-87	Signal
PIN 1	YE	WH	A+
PIN 2	GY	BN	B+
PIN 3	GN	GN	B-
PIN 4	WH	Z+	
PIN 5	RD	GY	Z-
PIN 6	BU	PK	supply voltage GND
PIN 7	BN	BU	+24 VDC
PIN 8	PK	RD	A-

Quadrature Interface

Transmission standard of A/B/Z	RS422 / 5 V or 24 V Push-Pull	
Max. pulse frequency at power-on (Initialization)		
High speed mode	156	kHz
Low speed mode (standard)	78	kHz
Max. operation speed		
High speed mode	2.2	m/s
Low speed mode (standard)	1.1	m/s
Update rate internal	16	kHz
Frequency A/B-signal	depends on transducer's velocity	
Missing increments when exceeding the max. operation speed	none	
Length Z-pulse	1 increment	

Type designations	TLM xxxx xxx 8xx xxx Quadrature Interface	
Electrical Data		
Defined electrical range (dimension B)	0050 to 4500	mm
Absolute linearity	$\leq \pm 30 \mu\text{m}$	
Output signal	digital	
Resolution	≤ 1 digit	
Reproducibility	≤ 2 digits	
Hysteresis	≤ 1 digit	
Supply voltage	$24 \pm 20 \%$ reverse polarity protected	VDC
Supply voltage ripple	max. 10 %	Vpp
Current draw	≤ 100 typical	mA
Output update rate	16	kHz
Shielding	connected to housing	
Temperature coefficient	≤ 20	ppm/K
Overvoltage protection	40 (Transzorb protection diodes)	VDC
Reverse voltage	yes	
Insulation resistance (500 V, 1 bar, 2 s)	≥ 10	M Ω
Mechanical Data		
Dimensions	see drawing	
Physical length (dimension A)	Dimension B + 160	± 2 mm
Environmental Data		
Operating temperature range	-40...+85	$^{\circ}\text{C}$
Storage temperature range	-40...+100	$^{\circ}\text{C}$
Operating humidity range	0...100	%R.H.
Shock per DIN IEC68T2-27	100 (11 ms)	g
Vibration per DIN IEC68T2-6	20 (5...2000 Hz, $A_{\text{max}} = 0,75$ mm)	g
Protection class per DIN 40050 IEC 529	IP67 with fastened connector IP68 with cable connection	
Mechanical data when used with unguided position marker		
Traverse speed of position marker	unlimited	ms^{-1}
Traverse acceleration of position marker	unlimited	ms^{-2}
Life	unlimited (mechanical)	movements
Standard defined electr. range (dimension B)	0050 up to 1000 in 50 mm steps, 1000 up to 2000 in 100 mm steps, 2000 up to 4500 in 250 mm steps; other lengths in 10 mm steps on request	
CE-conformity		
Emissions	RF noise field strength EN 55011 Group 1 Class A	
Noise immunity	ESD EN 61000-4-2 HF-field EN 61000-4-3 BURST EN 61000-4-4 Conducted disturbances EN 61000-4-6	

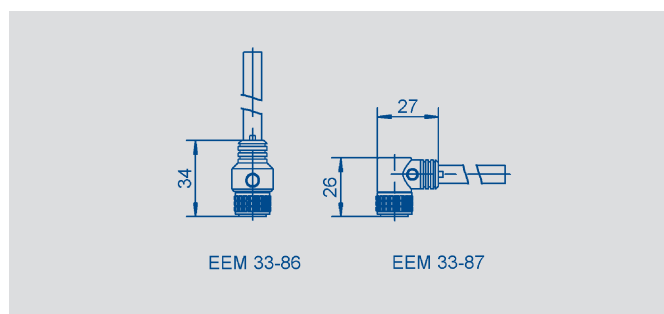
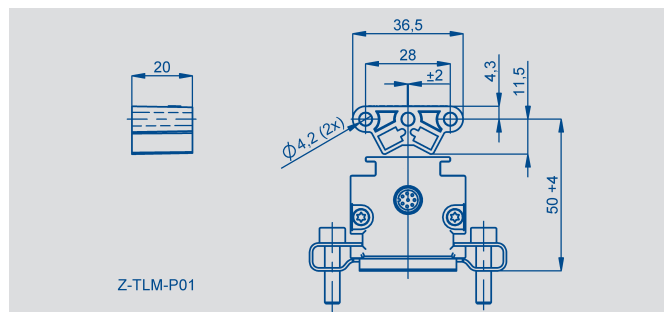

Ordering specifications				Electrical Interface			
				8: Incremental Quadrature Interface			
				Output signal Incremental Interface 8XX 4: Resolution 5 µm, variable frequency, high speed mode, power-on burst 6: Resolution 1 µm, variable frequency, high speed mode, power-on burst 7: Resolution 5 µm, variable frequency, low speed mode, power-on burst 9: Resolution 1 µm, variable frequency, low speed mode, power-on burst			
				Incremental Interface 8XX 1: 5V level, differential =line driver (A+ A- B+ B- Z+ Z-) 2: 5V level, single line = fixed level = Push-Pull on request 5: 24 V level, single line = fixed level = Push-Pull on request			
				Electrical connection 102: 8 pin round connector M12x1 201: NT standard cable 1 m 203: NT standard cable 3 m 205: NT standard cable 5 m			
T	L	M	0 8 0 0	0 0 1	8 7 1	1 0 2	
Series			Defined electr. range Several standard lengths from 0050 bis 4500 mm	Mech. configuration 001: Profile design			

Included in delivery

Mounting clamps Z46
 electrically isolating incl. fillister
 head screws

Required accessories

Floating position marker
 Z-TLM-P01, Art.No. 005651,
 Z-TLM-P04, Art.No. 005654;
 Guided position marker
 Z-TLM-P05, Art.No. 005655;
 Other position markers on re-
 quest

Recommended accessories

Connector M12x1, 2 m cable,
 EEM 33-86, IP67,
 Art.No. 005629;
 Angled connector M12x1,
 2 m cable, EEM 33-87, IP67,
 Art.No. 005630;
 Connector with longer cable
 length on request

Available on request

Standard cable 10 m
 Specific connectors
 Without power-on burst
 Burst on demand
 Z-pulse teach-in
 Other resolutions
 Analogue, digital and fieldbus
 interface see separate data
 sheet

Important

Avoid equalizing currents in
 the cable shield caused by
 potential differences. Twisted
 pairs are recommended.